

# NP Series

FLUID PROCESSING AND TRANSFER SLIDING VANE PUMPS | PRODUCT BROCHURE



*Blackmer*

Where Innovation Flows





Facilities are constantly evolving. When new processes, products, materials, and ingredients get added or changed, you need versatile reliable pumps that can adjust and accommodate your facility as it evolves. You need Blackmer® NP Series Sliding Vane Pumps.

**VERSATILE  
SUSTAINED  
HIGH-LEVEL  
PERFORMANCE**

## Blackmer® NP Series Sliding Vane Pumps

### Versatile Fluid Processing and Transfer Pump

Blackmer NP Series Sliding Vane Pumps are specially designed to offer maximum versatility for handling a wide range of clean, non-corrosive viscous or shear sensitive fluids. The pumps come in 1.5 to 4-in port sizes with flow rates ranging from 2 to 525 gpm (8 to 1,985 L/min) and have a maximum differential pressure of 200 psi (13.79 bar). The key to the NP Series versatility are the many available sealing options – packing, lip seal, mechanical seal, and triple-lip seal. By accepting customer specified seals, the NP Series Pump can be a valuable pump in any facility.

These highly configurable pumps feature the Blackmer unique sliding vane rotor design that provides sustained high-level performance over a wide viscosity range. With optional features and materials, NP Series Sliding Vane Pumps can handle fluid temperatures up to 500°F (260°C) and maximum viscosities up to 100,000 SSU (22,000 cP). Slow operating speeds and non-pulsating flow minimizes shear and agitation of the fluid. NP models feature 90° porting, and NPH models have 180° porting, with heating jackets available for all models.

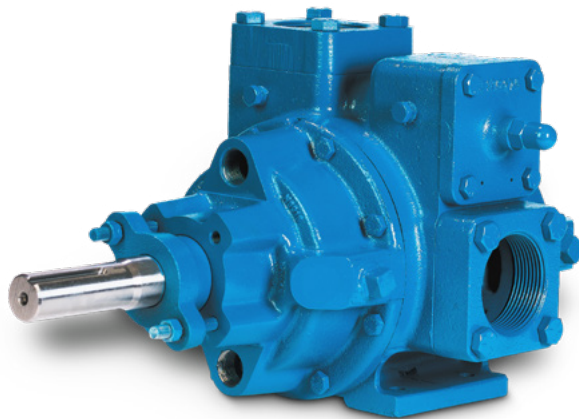

JACKETED NP2  
SLIDING VANE  
PUMP

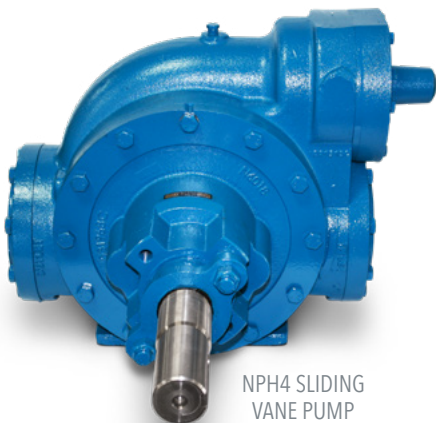

NPH4 SLIDING  
VANE PUMP

	STANDARD MATERIALS LIMITS	OPTIONAL MATERIALS LIMIT
Maximum Temperature	240°F (115°C)	500°F (260°C)
Maximum Viscosity	20,000 SSU (4,250 cP)	100,000 SSU (22,000 cP)
Maximum Differential Pressure	150 psi (10.3 bar) Open Rotor	200 psig (13.8)
	125 psi (8.6 bar) Closed Rotor	
Maximum Working Pressure	175 psig (12.1 bar)	225 psig (15.5 bar)

## Integrated Unit Assembly

Blackmer® fully Integrated Unit Assemblies are the pre-engineered and pre-designed drop-in pumping solution. These unit assemblies, include motor, gearbox, baseplate, NP1.5, 2, 2.5, 3, 4-inch Pump and coupling safety covers. No alignment required with these pre-configured fully Integrated Unit Assemblies as they are ready for immediate drop-in installation.

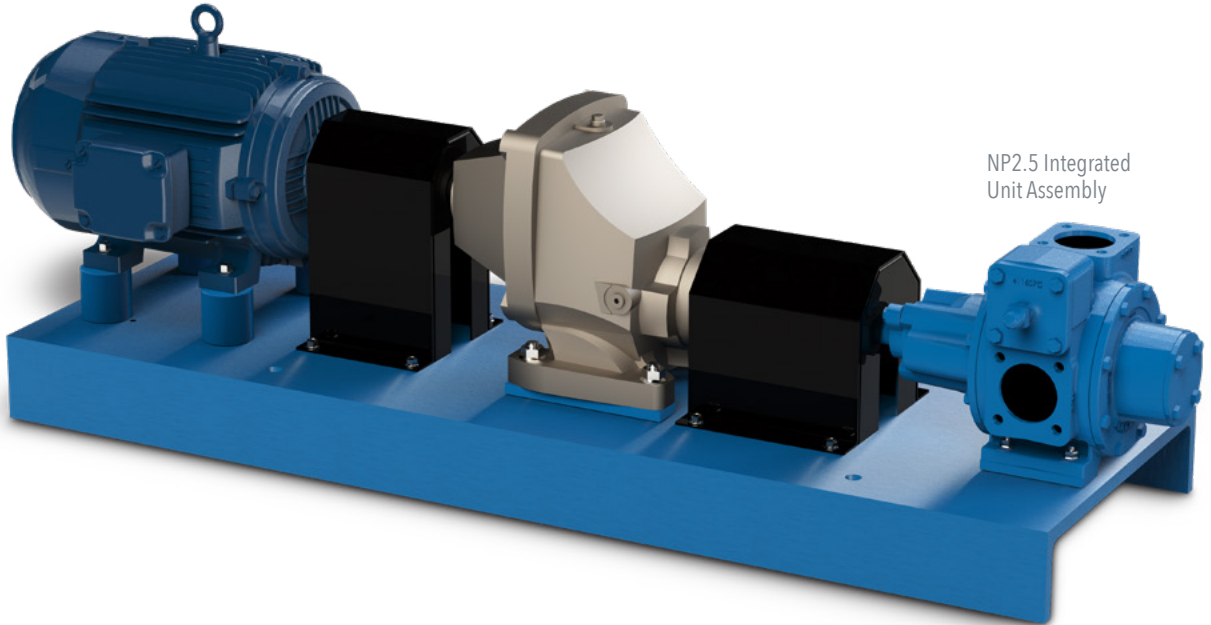

## Self-Priming, Dry Run & Other Benefits of Blackmer Vane Pumps

Blackmer positive displacement pumps have revolutionized the pumping industry with their unique sliding vane pump technology. This revolutionary rotary vane design allows the pumps to self-adjust for wear to help maintain flow rates. This sliding vane pump design creates excellent self-priming and dry-run capabilities, while also providing sustained performance and trouble-free operation.

- Maintain consistent flow rates throughout the life of the pump due to unique sliding vane pump design that self-adjusts for wear
- Sliding vane design provides sustained performance and trouble-free operation
- Easy maintenance: vanes can be easily replaced without removing the pump from the piping system
- Low maintenance and low life-cycle costs, pumps are renewable and repairable
- Highly efficient, sliding vane pumps require less horsepower than other pumps, meaning spending less on motors initially and less on electricity to power the pump
- Excellent at self-priming, eliminates expensive priming systems
- Extended dry-run capability, eliminates nuisance current monitoring systems
- High suction lift abilities that exceed 25 feet (7.6 meters)

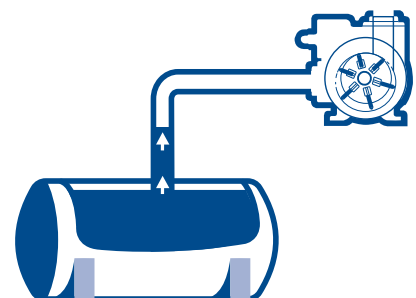
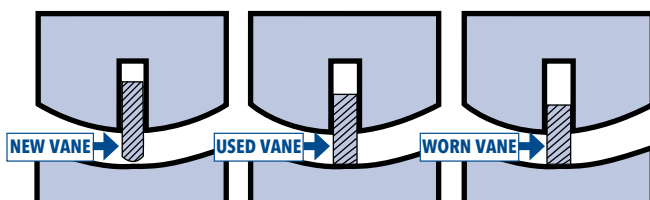

# BLACKMER® NP SERIES SLIDING VANE PUMPS

## Rotor

Developed with minimal clearance to improve inlet performance. The closed rotor design allows for line stripping, priming evacuated piping systems and vertical lift of fluid to the pump inlet. Optional open rotor (as shown) available for highly viscous applications.

## Sealing Options

- Packing
- Lip Seal
- Customer Specified Seal
- Single Mechanical Seal
- Double Mechanical Seal
- Triple-Lip Cartridge Seal

## Jacketing - Optional

Keep fluids moving without hardening, with optional jacketing. Electric heater ports or heating jackets for use with steam or hot oil are available. These options heat the pump for highly viscous fluids and control the bearing temperature.

## Unique Sleeve Bearing Design

Ensure longer bearing life by minimizing temperature rise. The unique head and bearing design allows a small quantity of fluid to flow from the discharge side of the pump to the bearings. This continuous flow of fluid over the bearing surfaces creates a protective hydrodynamic film. The pumpage is then drawn to the suction side of the pump through passages in the heads.

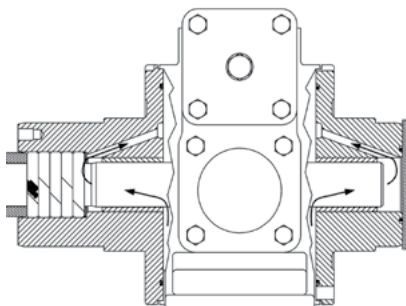

## Drain Plugs

Allows for easy draining, this feature is standard on ductile iron casing, and optional on cast iron casing.



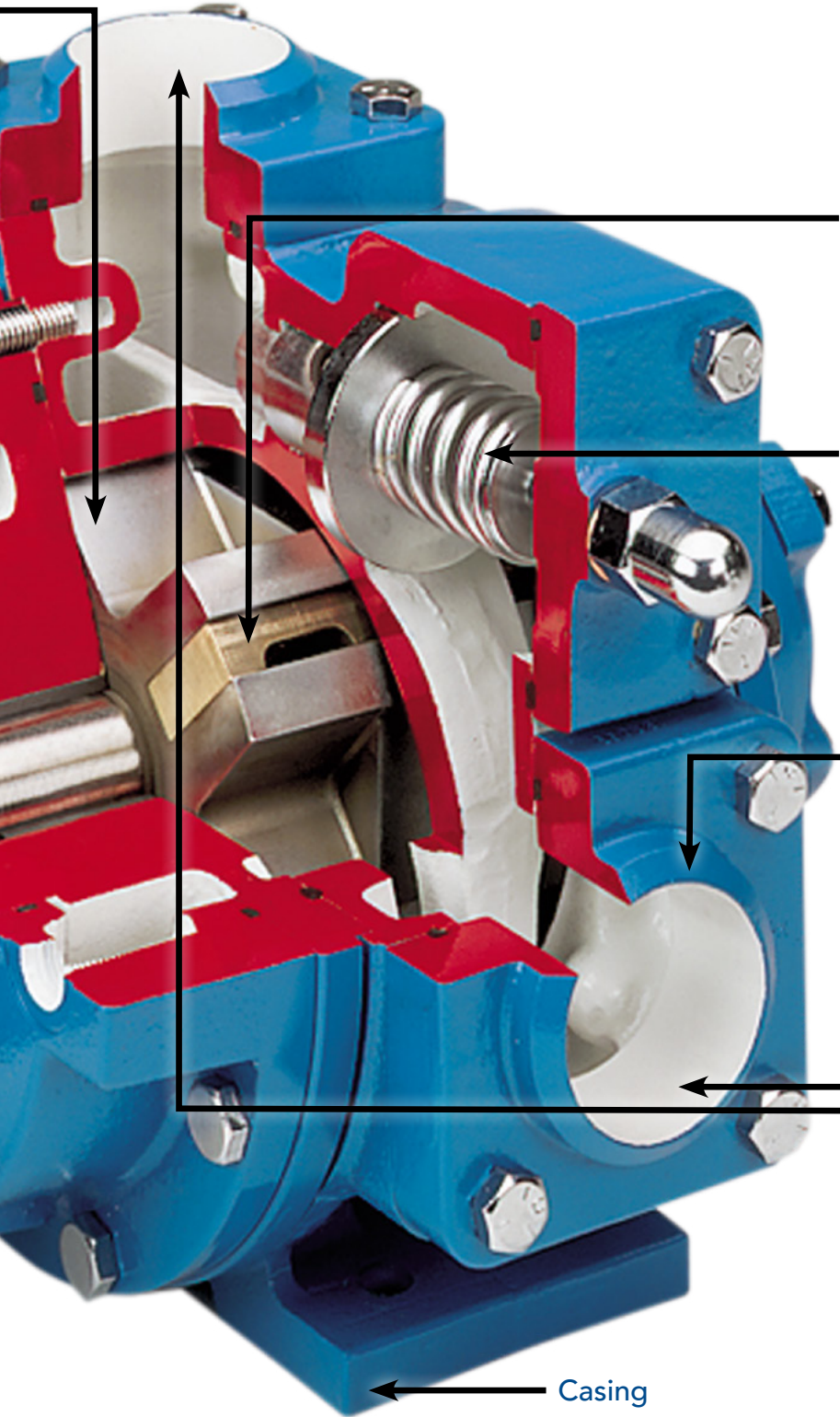

**Vanes**

Non-metallic Duravanes provide exceptional sealing and self-adjust to maintain performance over the operating life of the pump. Optional laminate, cast iron and bronze vanes are available.

**Relief Valve**

Designed to protect the pump from excessive pressure, the steel spring actuated cast iron relief valve is also adjustable. Optional corrosion resistant relief valve with stainless steel spring is available.

**Flanges**

NP 1.5" model features NPT tapped casing ports.  
NP(H) 2", 2.5", 3", & 4" models feature standard NPT tapped companion flanges. Optional weld neck and ANSI CL 150 flanges also available.

**Porting Orientation**

NP 1.5 to 4-in models feature 90° porting, and NPH 2 to 4-in models feature horizontal 180° porting.

**Casing**

Cast iron is standard. All NPH sizes and NP 4 models are ductile iron.

## Applications

- Clean, non-corrosive viscous or shear sensitive fluids offering high level performance over a wide viscosity range.
- Wax, Greases, Glues, Solvents (VOCs), Adhesives, Chocolate, Creosote, Syrup, Asphalt / Bitumen, Molasses, Aqueous Film Forming Foam, Edible Oils, Black Liquor, Sodium Silicate, Tallow, Soaps, Oil Batching, Gear Lube Oil and AFFF.

## MAXIMUM OPERATING LIMITS

Pump Model	Nominal Flow Rate Range	Viscosity	Minimum Operating Temperature	Maximum Operating Temperature	Min./Max. Speed	Maximum Differential Pressure	Maximum Hydrostatic Pressure
	gpm (L/min)	SSU (cP)	°F (°C)	°F (°C)	RPM	psi (bar)	psi (bar)
NP1.5	2 - 47 (8 - 178)	100,000 (22,000)	-25 (-32)	500 (260)	70-640	200 (13.79)	300 (20.68)
NP2/ NPH2	10 - 77 (38 - 291)	100,000 (22,000)	-25 (-32)	500 (260)	70-640	200 (13.79)	300 (20.68)
NP2.5/ NPH2.5	20 - 136 (76 - 515)	100,000 (22,000)	-25 (-32)	500 (260)	70-640	200 (13.79)	300 (20.68)
NP3/ NPH3	60 - 276 (227 - 1,045)	100,000 (22,000)	-25 (-32)	500 (260)	70-640	200 (13.79)	300 (20.68)
NP4/ NPH4	220 - 525 (833 - 1,985)	100,000 (22,000)	-25 (-32)	500 (260)	70-520	200 (13.79)	300 (20.68)

**Note:** Optional materials of construction may be required to meet specific application requirements – refer to Blackmer Material of Construction Sheets. For operating limits that exceed those listed – consult factory.

## MAINTENANCE KITS

MODEL(S)	DESCRIPTION	PART NUMBER
NP1.5	Kit - Maintenance	898928
NP2, NPH2	Kit - Maintenance	898929
NP2.5, NPH2.5	Kit - Maintenance	898930
NP3, NPH3	Kit - Maintenance	898931
NP4, NPH4	Kit - Maintenance	898932



# Blackmer® NP Series Sliding Vane Pumps | Performance

## Nominal Flow Rate Range

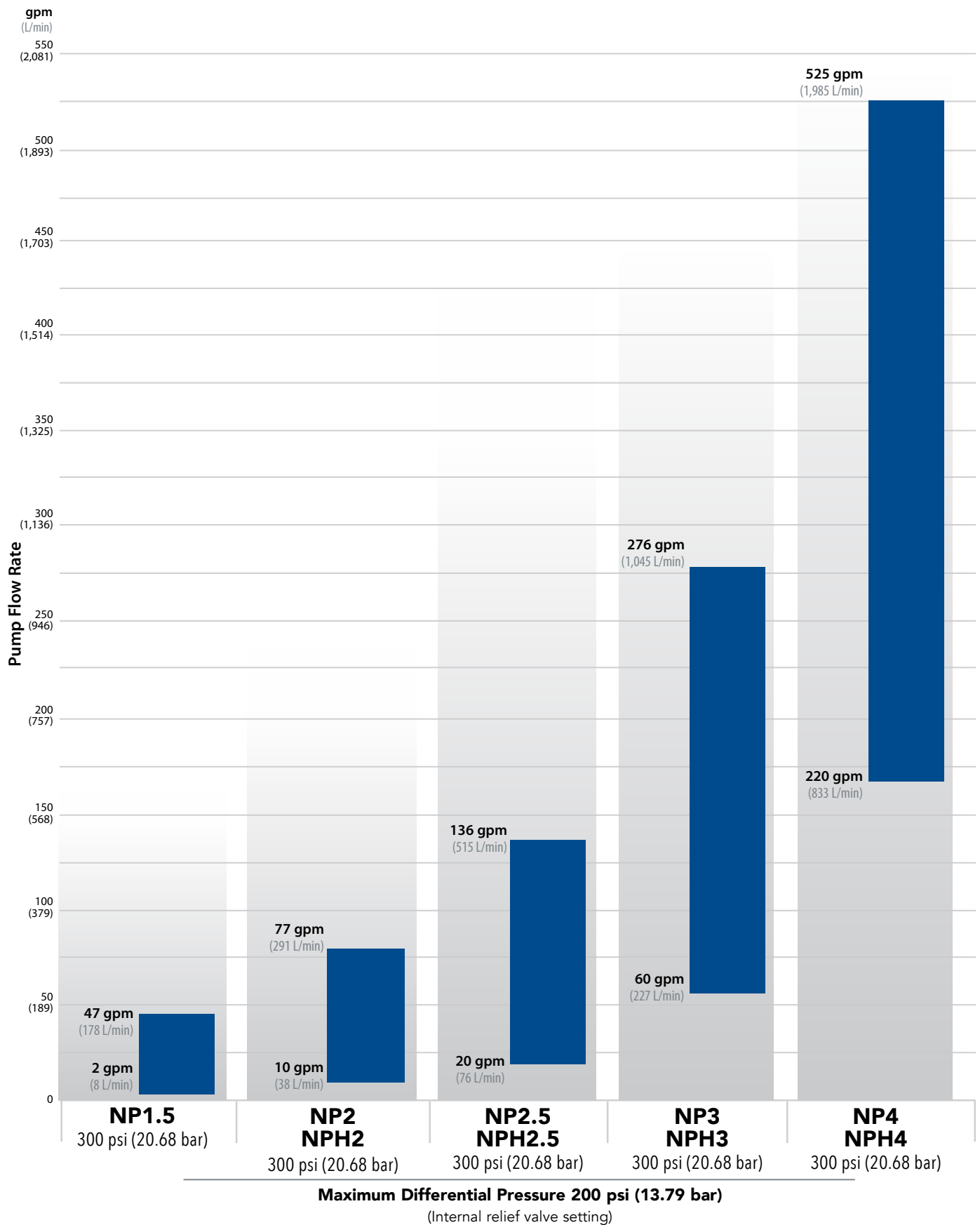



PSG Grand Rapids  
1809 Century Avenue SW  
Grand Rapids, MI 49503-1530  
USA

P: +1 (616) 241-1611

[info@blackmer.com](mailto:info@blackmer.com)

[psgdover.com/blackmer](http://psgdover.com/blackmer)



Where Innovation Flows

103-001 01/25-A4

Authorized PSG® Partner:

Copyright 2025 PSG®, a Dover company