



www.blackmer.com

TYPE	SIZE	UNIT STYLE
GX	2.5B	PO

DIMENSIONS 101-106

Section	101
Effective	February 2003
Replaces	October 1995
Page	1/3

RIGHT HAND ROTATION. FOR LEFT HAND ROTATION, SHAFT PROJECTION IS OPPOSITE THAT SHOWN.

MAXIMUM INPUT SHAFT OFFSET "Y" FROM CENTER LINE OF PUMP

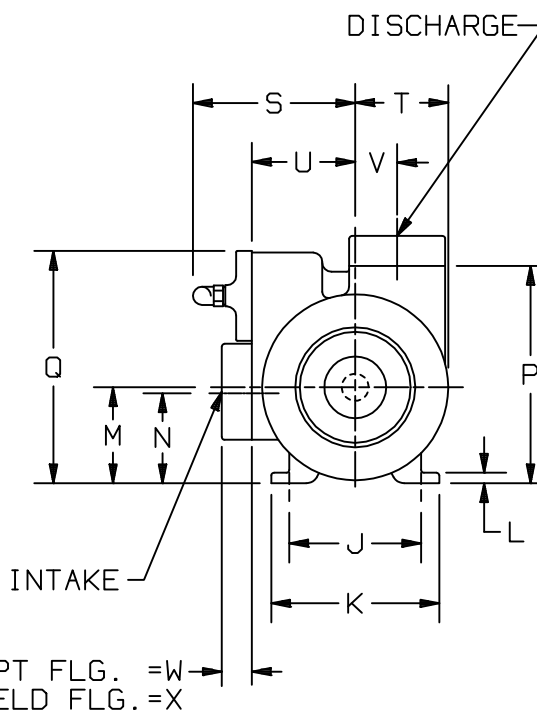
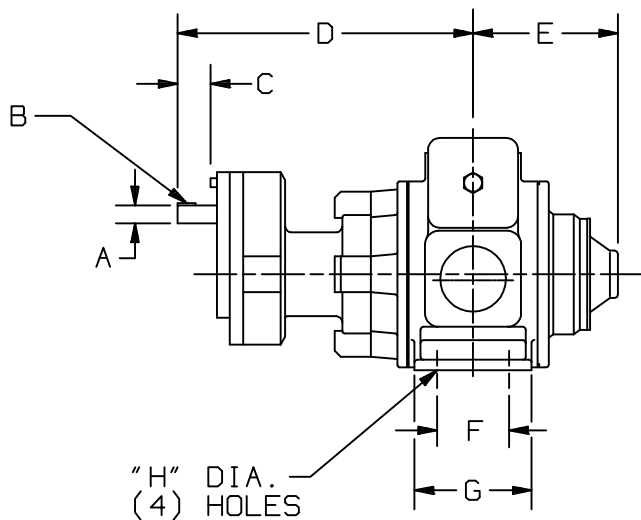
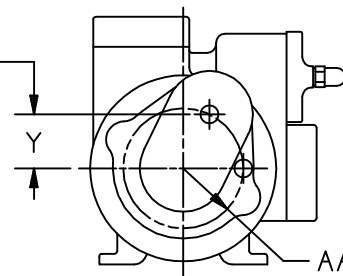

MOTOR			UNITS	DIMENSIONS									
FRAME SIZE				A	B	C	D	E	F	G	H	J	K
			IN	3/4	3/16	1 3/8	12 5/16	6	3	4 7/8	7/16	5 1/2	7
			MM	19,1	4,8	34,9	312,7	152,4	76,2	123,8	11,1	139,7	177,8
				L	M	N	P	Q	R	S	T	U	V
			IN	7/16	4	3 3/4	9 1/16	9 5/8	—	6 13/16	3 7/8	4 5/16	1 3/4
			MM	11,1	101,6	95,3	230,2	244,5	—	173	98,4	109,5	44,4
				W	X	Y	Z	AA	BB	CC	DD	EE	FF
			IN	1 3/16	1 1/4	2 1/4	—	2 1/2	—	—	—	—	—
			MM	30,2	31,8	57,1	—	63,5	—	—	—	—	—
				GG	HH					PUMP WEIGHT	WITH STD. FLANGES		
			IN	—	—					LBS	130		
			MM	—	—					KG	59		



www.blackmer.com

TYPE
GX
RIGHT HAND
ROTATION

SIZE
2.5B

UNIT
STYLE
GX

DIMENSIONS 101-106
Section 101
Effective February 2003
Replaces MARCH 1999
Page 2/3

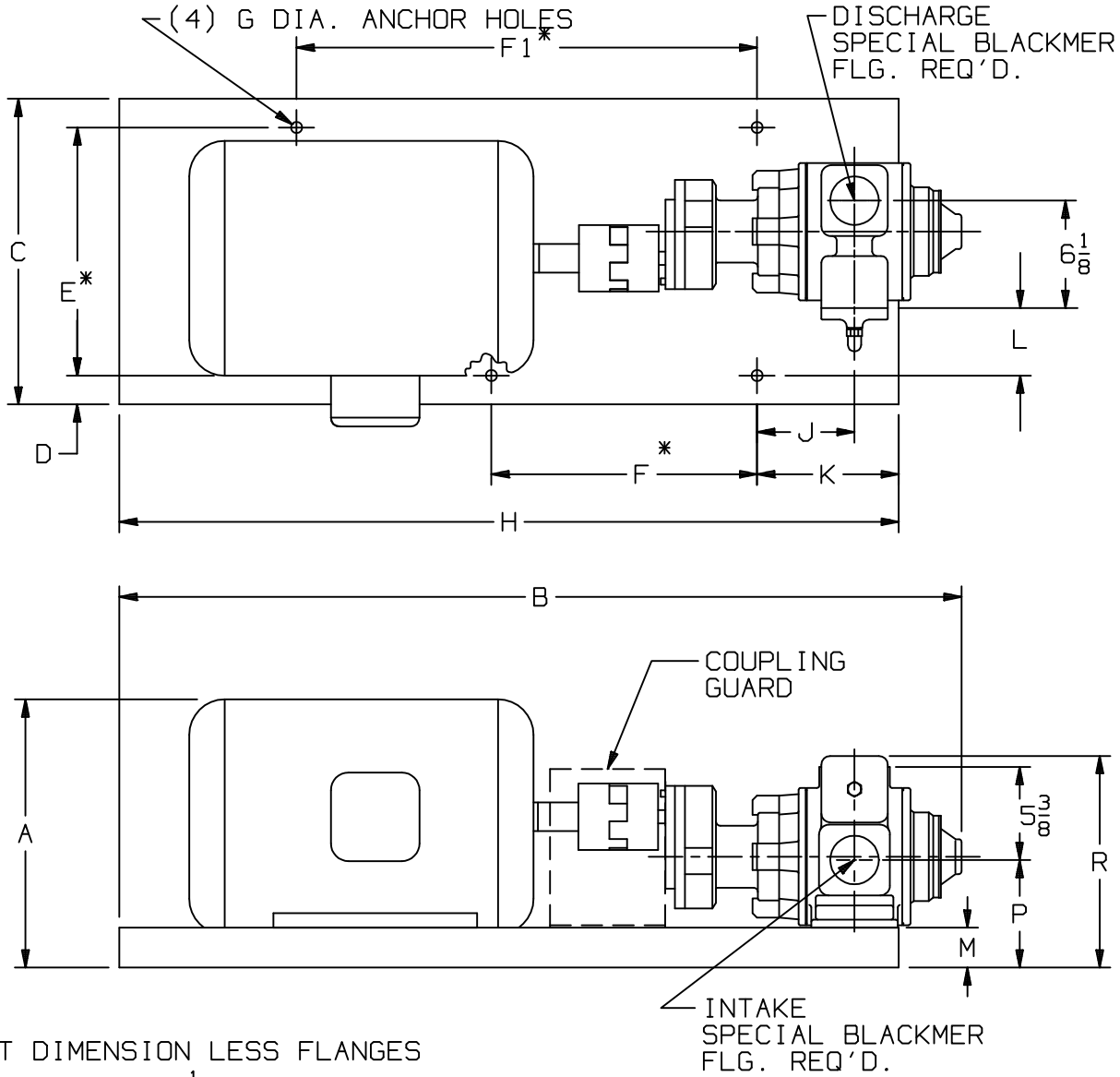

UNIT DIMENSION LESS FLANGES

* TOLERANCE $\pm \frac{1}{8}$

TOLERANCE ON OTHER DIMENSIONS $\pm \frac{1}{4}$

"A" DIMENSION LESS EYEBOLT

FLG. HT: $2\frac{1}{2}$ " NPT- $1\frac{3}{16}$

$2\frac{1}{2}$ " WELD- $1\frac{1}{4}$

MOTOR			BASE NO.	DIMENSIONS														
FRAME SIZE				A	B	C	D	E	F	F1	G	H	J	K	L	M	P	R
143T			901634	9 1/2	31	13	1 1/2	10	12	12	7/16	28	3 1/2	6	2 5/8	1 3/4	5 1/2	11 3/8
145T			901634	9 1/2	31 5/8	13	1 1/2	10	12	12	7/16	28	3 1/2	6	2 5/8	1 3/4	5 1/2	11 3/8
182T			901635	11 3/8	35 5/8	13	1 1/2	10	12	12	7/16	28	3 1/2	6	2 5/8	1 3/4	5 1/2	11 3/8
184T			901635	11 3/8	37	13	1 1/2	10	12	12	7/16	28	3 1/2	6	2 5/8	1 3/4	5 1/2	11 3/8
213T			901636	12 7/8	38 1/4	14 3/4	2 3/8	10	12	12	7/16	33	3 1/2	6	2 5/8	1 3/4	5 1/2	11 3/8
215T			901636	12 7/8	39 3/4	14 3/4	2 3/8	10	12	12	7/16	33	3 1/2	6	2 5/8	1 3/4	5 1/2	11 3/8
254T			901365	15 1/4	48 1/4	17 1/4	1 5/8	14	15	26	5/8	44	5 1/2	8	3 7/8	2 1/4	6	12 1/2
256T			901365	15 1/4	48 1/4	17 1/4	1 5/8	14	15	26	5/8	44	5 1/2	8	3 7/8	2 1/4	6	12 1/2

DIMENSIONS 101-106

Section 101
 Effective February 2003
 Replaces March 1999
 Page 3/3

TYPE
 GX
 LEFT HAND
 ROTATION

SIZE
 2.5B

UNIT
 STYLE
 GX

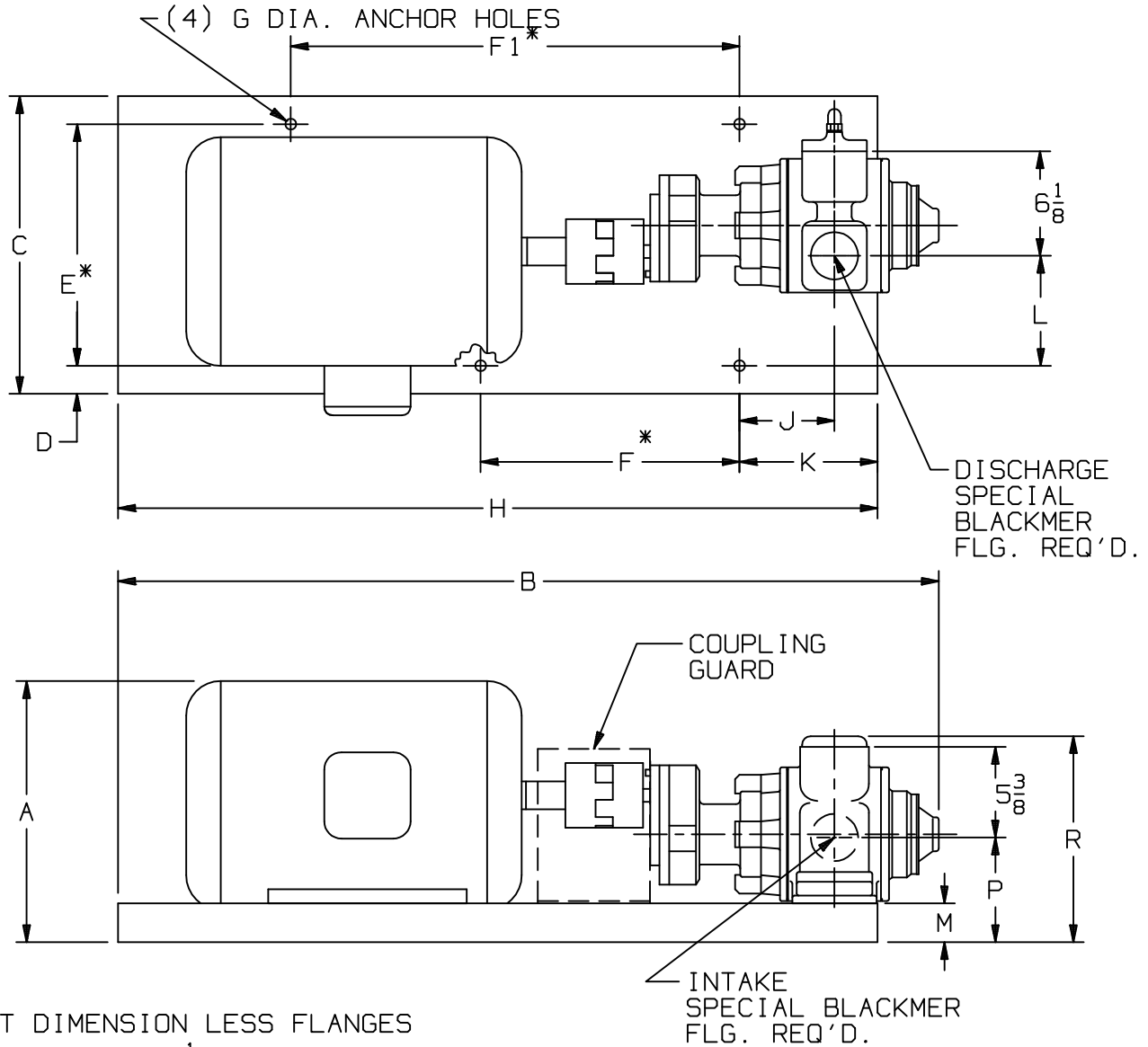

UNIT DIMENSION LESS FLANGES

* TOLERANCE $\pm \frac{1}{8}$

TOLERANCE ON OTHER DIMENSIONS $\pm \frac{1}{4}$

"A" DIMENSION LESS EYEBOLT

FLG. HT: 2 1/2" NPT-1 3/16

2 1/2" WELD-1 1/4

MOTOR			BASE NO.	DIMENSIONS														
FRAME SIZE				A	B	C	D	E	F	F1	G	H	J	K	L	M	P	R
143T			901634	9 1/2	31	13	1 1/2	10	12	12	7/16	28	3 1/2	6	5 1/8	1 3/4	5 1/2	11 3/8
145T			901634	9 1/2	31 5/8	13	1 1/2	10	12	12	7/16	28	3 1/2	6	5 1/8	1 3/4	5 1/2	11 3/8
182T			901635	11 3/8	35 5/8	13	1 1/2	10	12	12	7/16	28	3 1/2	6	5 1/8	1 3/4	5 1/2	11 3/8
184T			901635	11 3/8	37	13	1 1/2	10	12	12	7/16	28	3 1/2	6	5 1/8	1 3/4	5 1/2	11 3/8
213T			901636	12 7/8	38 1/4	14 3/4	2 3/8	10	12	12	7/16	33	3 1/2	6	5 1/8	1 3/4	5 1/2	11 3/8
215T			901636	12 7/8	39 3/4	14 3/4	2 3/8	10	12	12	7/16	33	3 1/2	6	5 1/8	1 3/4	5 1/2	11 3/8
254T			901365	15 1/4	48 1/4	17 1/4	1 5/8	14	15	26	5/8	44	5 1/2	8	6 3/8	2 1/4	6	12 1/2
256T			901365	15 1/4	48 1/4	17 1/4	1 5/8	14	15	26	5/8	44	5 1/2	8	6 3/8	2 1/4	6	12 1/2