

BLACKMER PARTS LIST

PUMP MODEL: X4B

961921 PARTS LIST
Page 1 of 2 101-B08

Section 101
Effective Oct 2024
Replaces Jul 2019

Keep with Instructions 101-B00 for Installation, Operation and Maintenance

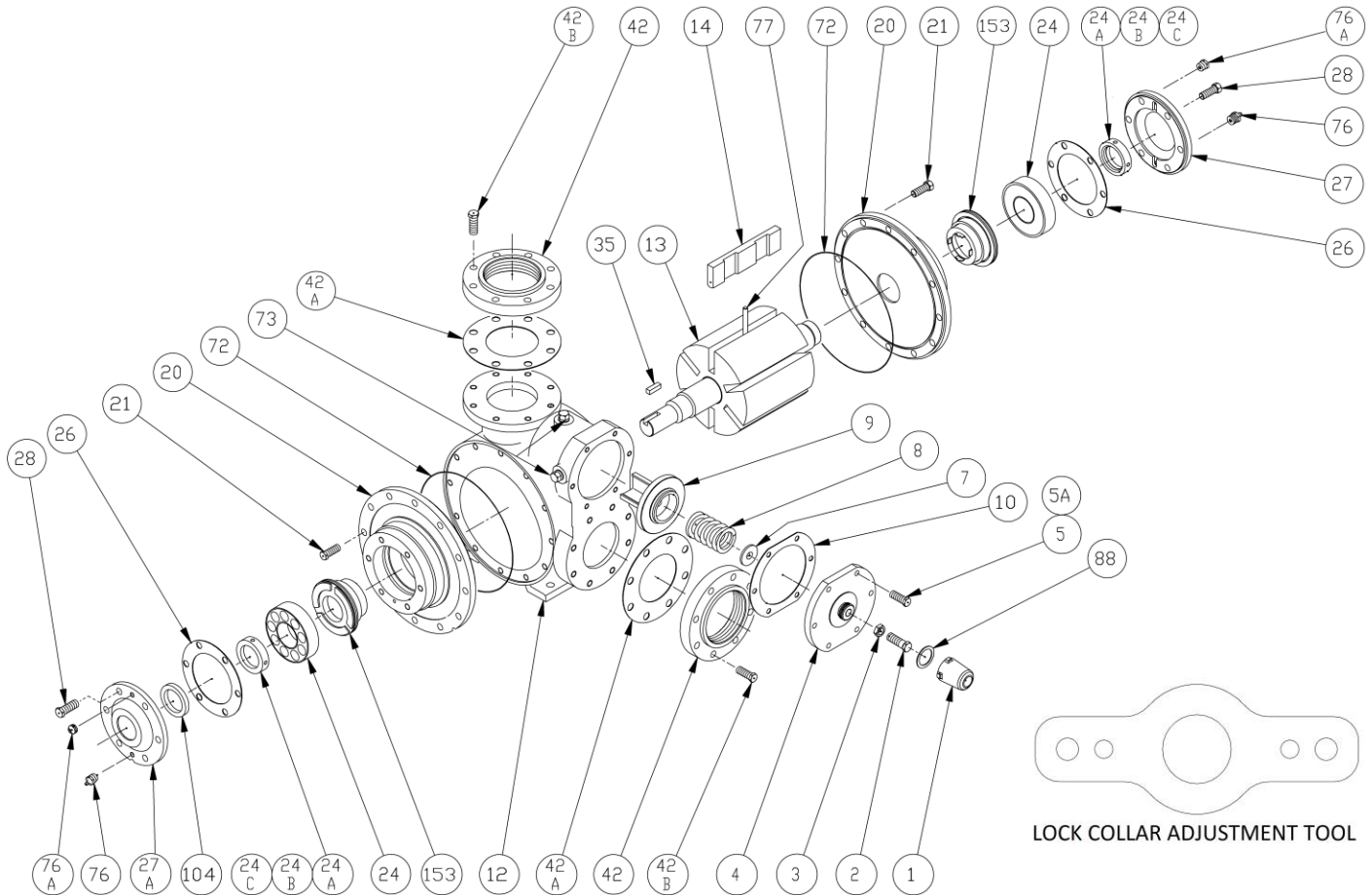

Ref. No.	Description	Parts per Pump	Part No.	Ref. No.	Description	Parts per Pump	Part No.
1	Cap - Relief Valve (R/V)	1	413957	24	Ball Bearing	2	¹ 903182
2	Adjusting Screw - R/V	1	436307	24A	Lock Collar - Bearing	2	^{1,2} 721937
3	Locknut - Adjusting Screw	1	436355				
4	Cover - R/V	1	411904	24C	Jam Nut	4	^{1,2} 922923
5	Capscrew - R/V Cover	6	920351	26	Gasket - Bearing Cover	2	¹ 386950
7	Spring Guide - R/V	1	426355	27	Bearing Cover - Outboard	1	041905
8	Spring - R/V (36-50 psi)	1	476303	27A	Bearing Cover - Inboard	1	041903
	Spring - R/V (51-75 psi)		476310	28	Capscrews - Bearing Cover	12	920491
	Spring - R/V (76-110 psi)		476305	35	Key - Shaft, Square	1	^{1,3} 909149
	Spring - R/V (111-125 psi)			42	Flange - 4" NPT (Std.)*	2	651900
9	Valve - R/V (Std.)	1	456315	42A	Gasket - NPT Flange (Std.)	2	¹ 381904
	Valve - R/V (Nickel Plated)		456300	42B	Capscrews - NPT Flange (Std.)	16	920532
10	Gasket - R/V Cover	1	¹ 531903	72	O-Ring - Head (FKM) (Std.)	2	¹ 702024
12	Cylinder	1	021906		O-Ring - Head (PTFE)		702093
			261950		O-Ring - Head (Buna-N)		702023
14	Vane - Duravane (Std.)	6	¹ 091924	73	Gage Plug	2	908198
	Vane - EC Cast Iron		091952	76	Grease Fitting	2	317815
	Vane - EC Laminate		091931	76A	Grease Relief Fitting	2	701992
20	Head	2	031908	77	Push Rod	3	¹ 121905
21	Capscrews - Head	24	920510	88	Gasket - R/V Cap	1	¹ 533908
				104	Grease Seal	1	¹ 904190
					Kit - Maintenance		898959
					Lock Collar Adjustment Tool		903099

¹ Included in Maintenance Kit * See Page 2 for Weld / ANSI flange options. SS = Stainless Steel. EC = Extra-Clearance.

² Earlier models of the X4B are not fitted with Bearing Lock Collars. Lock Collars may be fitted to older models.

³ Pumps prior to April 2008 used Woodruff key 909135, included in Maintenance kits.

MECHANICAL SEALS

Ref. No.	Part Name	Parts Per Pump	Part No.
153	Mechanical Seals Complete - Cast Iron Stationary Seat, Carbon Seal Face, FKM O-Rings. (IVCV) (Std.)	2	¹ 336982
	Cast Iron Stationary Seat, PTFE O-Ring, Carbon Seal Face w/ PTFE Seal Ring. (IACT)		331973
	Stainless Steel Stationary Seat, PTFE O-Ring, Carbon Seal Face w/ PTFE Seal Ring. (WACT)		331901
	Cast Iron Stationary Seat, Carbon Seal Face, Buna-N O-Rings. (INCN)		336958
153D	O-Ring - Stationary (FKM)	2	711932
	O-Ring - Stationary (PTFE)		702090
	O-Ring - Stationary (Buna-N)		701945
153L	O-Ring - Rotating (FKM)	2	701967
	Seal Ring - Rotating (PTFE)		**
	O-Ring - Rotating (Buna-N)		701933

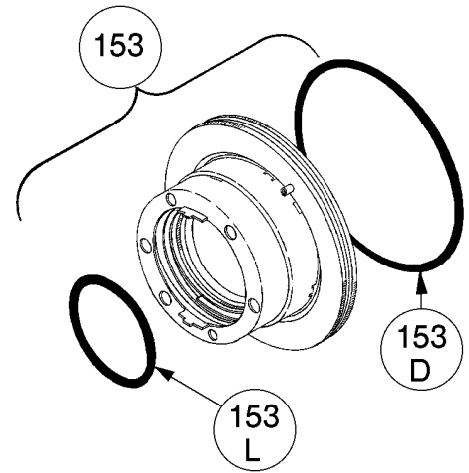

¹ Included in Maintenance Kit

**PTFE Rotating Seal Ring is not available as a separate part.

FLANGE OPTIONS

Ref. No.	Part Name	Parts Per Pump	Part No.
42	Flange - 4" Weld	2	651906
	Flange - 4" ANSI		651917
42B	Capscrews - Weld / ANSI Flange	16	920532
42C	O-Ring - Weld/ANSI Flg. (FKM)	2	702238
	O-Ring - Weld/ANSI Flg. (PTFE)		702239
	O-Ring - Weld/ANSI Flg (Buna-N)		702237

