

BLACKMER PARTS LIST

PUMP MODEL: TLGLF3C

960426
Page 1 of 2

PARTS LIST
501-D01

Section 501
Effective Oct 2024
Replaces Feb 2021

Keep this parts list with Installation, Operation and Maintenance Instructions 501-D00

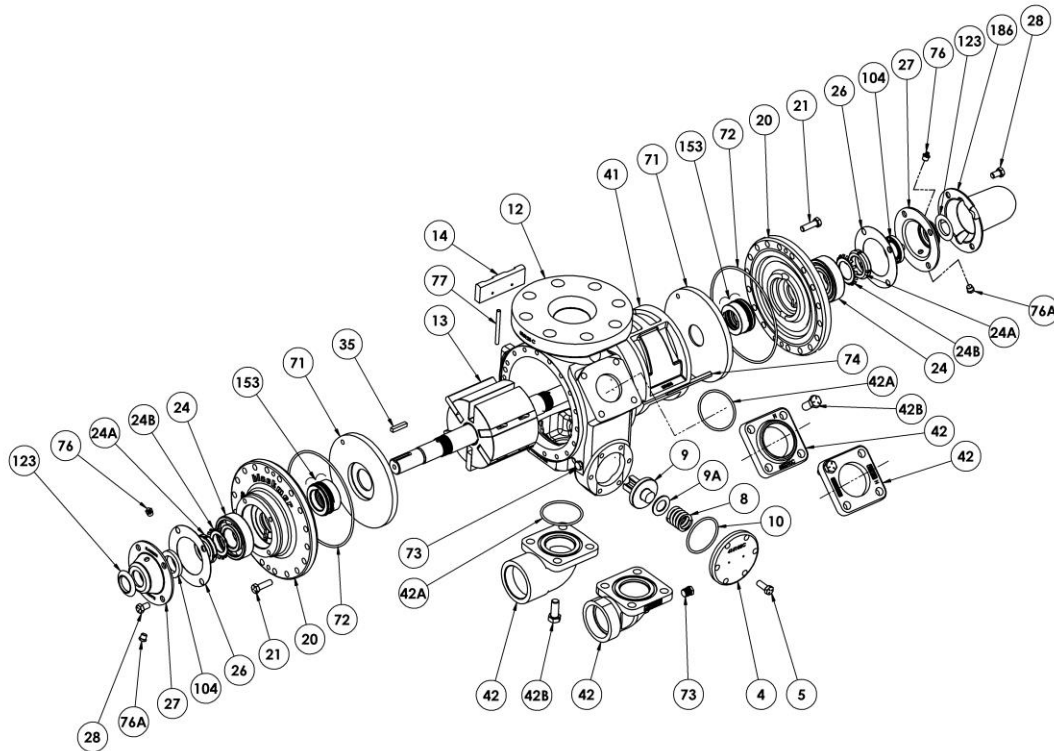

Ref. No.	Description	Parts Per Pump	Part No.	Ref. No.	Description	Parts Per Pump	Part No.	
4	Cover - Relief Valve (R/V)	1	415108	42	Flange - 2" NPT	1-2	652010	
5	Capscrew - R/V Cover	6	920331		Flange - 2" Slip-on Weld		652024	
8	Spring - R/V	1	¹ 471428		Flanged Elbow - 2" NPT		⁶ 655100	
9	Valve - R/V	1	⁴ 451460		Flanged Elbow - 2" Socket Weld		⁶ 655109	
9A	Relief Valve Shim, .035"	0-1	332907		Blank Flange for Auxiliary Inlet		652036	
	Relief Valve Shim, .075"		332937		Flanged Elbow - 2" NPT Stainless		655200	
10	O-Ring - R/V Cover	1	¹ 701919		Flanged Elbow - 2" Socket Weld SS		⁶ 655209	
12	Casing	1	015128		Flange - 2" Slip-on Weld Stainless		655224	
13	Rotor & Shaft Assembly ⁵	1	² 265147		O-Ring - Flange 2 5/8" x 2 7/8" (current)		2	^{1,3} 702004
14	Vane - Duravane	6	¹ 095132		O-Ring - Flange 2 1/2" x 2 3/4" (older pumps)			¹ 701919
20	Head	2	035132	42B	Capscrew - Flanges	4-8	920491	
21	Capscrews - Head	36	920351	Socket Capscrew - Elbow Flanges	920494			
24	Ball Bearing	2	¹ 903156	71	Disc	2	¹ 065121	
24A	Locknut - Bearing	2	² 903521	72	O-Ring - Head	2	¹ 711923	
24B	Lockwasher - Bearing	2	¹ 903522	73	Gage Plug	2	908198	
26	Gasket - Bearing Cover	2	¹ 383940	74	Key - Liner	1	² 185193	
27	Bearing Cover	2	041431	76	Grease Fitting	2	317815	
28	Capscrews - Bearing Cover	8	920285	76A	Grease Relief Fitting	2	701992	
35	Key - Shaft Current, .25 Sq.	1	¹ 909209	77	Push Rod	3	¹ 121608	
	Key - Shaft OBS, Woodruff		¹ 909130	104	Grease Seal	2	¹ 331918	
41	Liner	1	² 185101	123	Dirt Shield	2	¹ 701480	
				186	Shaft Protector	1	341601	
				—	Tool - Locknut	—	903091	
				—	Kit - Maintenance	—	898980	
				—	Kit - Maintenance with R/V	—	899225	
				—	Kit - Rebuild	—	899080	
				—	Kit - Rebuild with R/V	—	899125	

¹ Included in Maintenance Kit and Rebuild Kit

² Included in Rebuild Kit

³ Larger O-Ring introduced October 2002

⁴ Additional parts Included in Kits with R/V

⁵ Includes Ref. No. 24A & 24B

⁶ Socket Head Capscrew Specific

MECHANICAL SEAL – NH₃ OR DUAL SERVICE – SNCN (ID Code = QA)

Ref. No.	Part Name	Parts Per Pump	Part No.
153	Mechanical Seal Assembly	2	¹ 334439
153A	Stationary Seat (Steel)	2	**
153B	Seal Face (Carbon)	2	**
153C	Jacket Assembly	2	**
153D	O-Ring - Stationary (Buna-N)	2	711924
153E	O-Ring - Rotating (Buna-N)	2	711918

¹ Included in Maintenance Kit and Rebuild Kit

** NOTE: Mechanical Seal Ref. No. 153 is only sold as a complete assembly. Ref. Nos. 153A, 153B & 153C are not available as separate replacement parts.

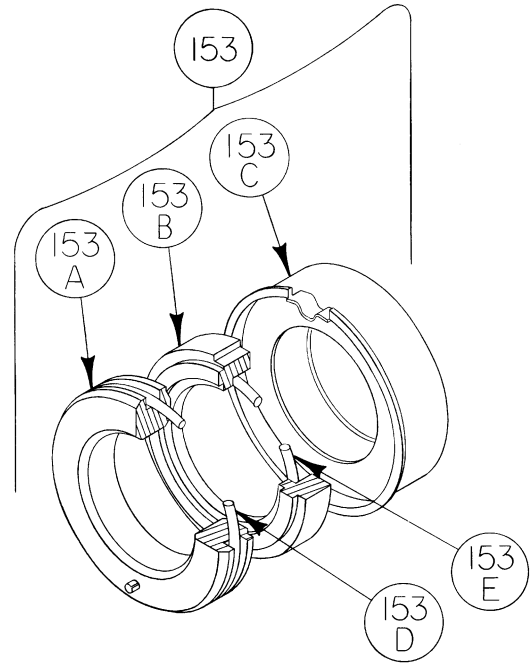

OPTIONAL HYDRAULIC MOTOR ADAPTER PARTS

REF. NO.	PART NAME	PARTS PER PUMP	PART NO. 1-1/4" Hyd Motor Shaft	PART NO. 1" Hyd Motor Shaft .
See Below	Hydraulic Motor Adapter Kit *	See Below	891458	891205
26A	Gasket – Hydraulic Motor Adapter	1	383940	383940
28A	Capscrew – Hydraulic Motor Adapter / Head	4	920369	920369
34	Coupling w/ Setscrew – straight key hyd. motor shaft	1	906967	906966
35	Key – Coupling	1	909184	N/A
76	Grease Fitting	1	317815	317815
76A	Grease Relief Fitting	1	701992	701992
135	Hydraulic Motor Adapter – SAE A Flange	1	041828	041827
135A	Capscrew – Adapter / Motor	2	920510	920510

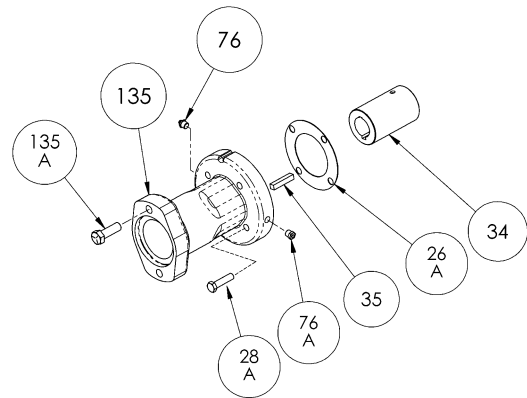

* Hydraulic Motor Adapter Kits shipped prior to Spring 2002 were a two two piece design – refer to page 206-C00.

