

V Series

INTERNAL GEAR PUMPS | PRODUCT BROCHURE

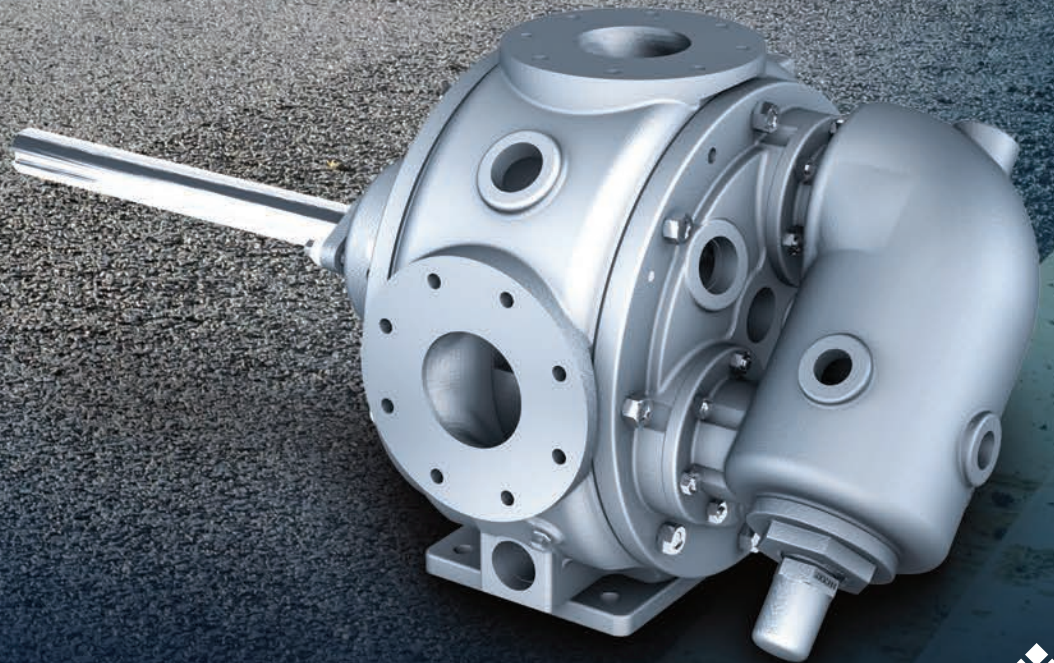

Where Innovation Flows



Specialty pumps designed for the rigors of pumping asphalt are required all along asphalt's production and supply chains. They can be found at refineries where raw asphaltic products are produced, terminals where various asphaltic products are stored, hot-mix plants where paving products are produced and roofing material manufacturing plants where shingles and other roofing materials are manufactured.

IDEAL FOR
HANDLING AND
TRANSFER OF
ASPHALT AND
BITUMEN PRODUCTS



EnviroGear® V Series Internal Gear Pumps

Asphalt pumps are at the heart of these and other systems that rely on asphaltic products as their base for production.

Because of the very nature of asphalt, it is extremely difficult to pump. But luckily for those involved, EnviroGear® V Series Internal Gear Pumps incorporate unique design enhancements that meet the challenges associated with pumping asphalt and offer a reliable solution to meet and exceed the operational demands of any facility. The latest innovation to the EnviroGear product line is a true advancement in the handling of asphaltic products: the V Series Internal Gear Pump.

V Series Pumps offer numerous features that enable them to overcome the many challenges inherent in the production and handling of asphalt and bitumen products. The main challenge in these operations is the most obvious one: as asphalt changes temperature it can range from a solid to a liquid with a wide variety of fluid characteristics depending on the chemical makeup, which makes it extremely difficult to pump with standard pumping technology. But luckily for those involved, the V Series isn't your standard pump.

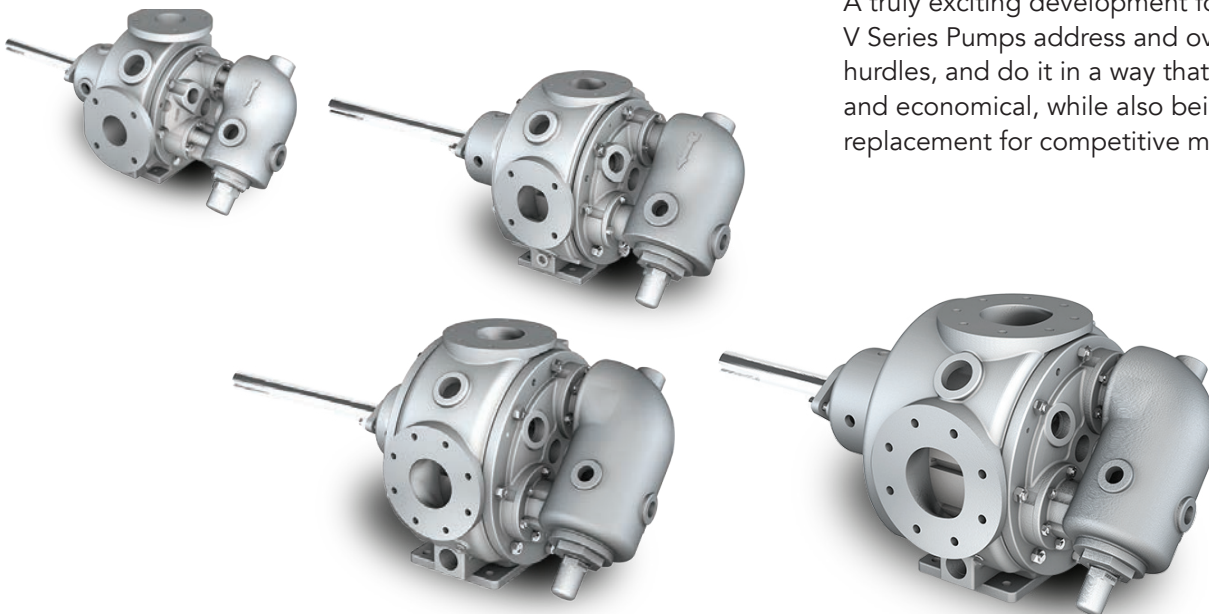

A truly exciting development for the industry, V Series Pumps address and overcome these hurdles, and do it in a way that is safe, reliable and economical, while also being a direct drop-in replacement for competitive models.

EnviroGear® V Series | Features

Jacketed

EnviroGear V Series Pumps offer up to 35% more jacket surface area than the competition, which improves system reliability by incorporating the following features:

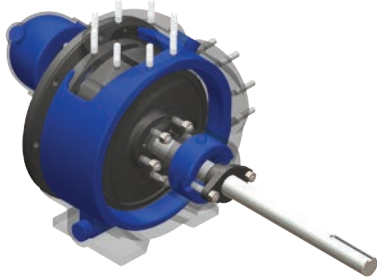
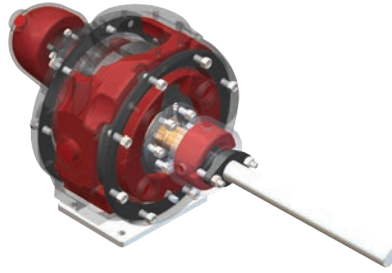

Image above represents typical jacket surface area of competitor pumps



V Series Jacketed Surface Area

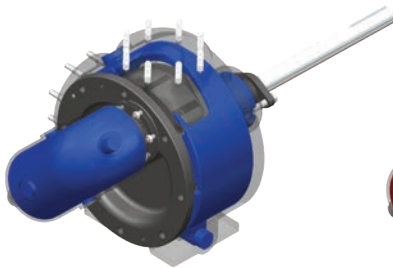

Image above represents typical jacket surface area of competitor pumps



V Series Jacketed Surface Area

- The unique ability to utilize the jacketed head and pressure relief valve (PRV) simultaneously
- Jacketing located behind the pump rotor, which removes a known cold spot that can result in hard startups and premature pump and seal failures
- The industry's largest jacketed surface area on the pump case and PRV that enables uniform heating whether using steam or hot oil
- Superior pump jacketing provides faster time to temperature of the product being pumped, getting back to production sooner

First Direct Replacement for Viking® 34 Series Pump & Parts

Replacing an existing Viking pump usually requires no modification to the piping, driver, baseplate or coupling, while also keeping flow rates unchanged. V Series components are also part-for-part interchangeable with the Viking 34 Series Pump and offer very specific design enhancements to improve reliability.

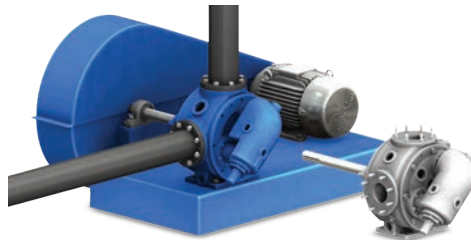

High-Strength Ductile Iron Gear Material as Standard

High-strength ductile iron is EnviroGear's standard offering with other hardened material component options available to provide improved pump life:

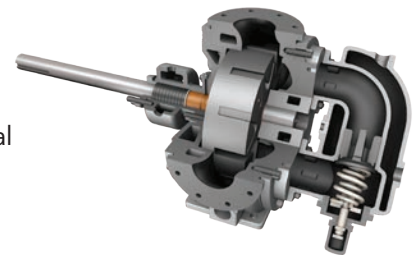

- Surface hardened case, head, rotor, idler and shaft
- Special high-temperature hardened steel idler pin
- Hardened cast iron idler bushing, RBS radial bushing, and stationary thrust washer

Rotatable Flanges

Allows the operator to use both right-handed and left-handed flange orientations as needed without additional lead times or costs associated with left-hand configuration pumps.

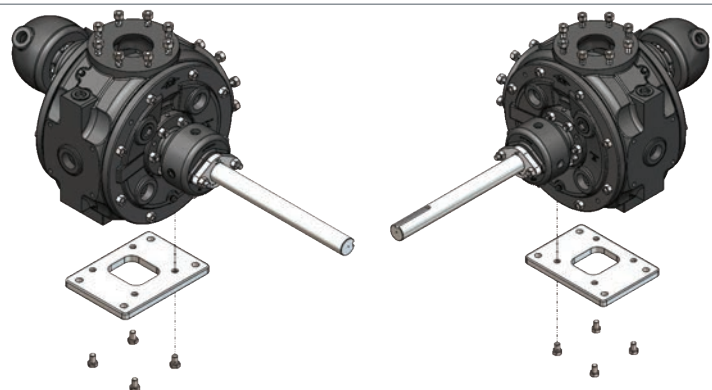

ENVIROGEAR® V SERIES INTERNAL GEAR PUMPS

Seal Chamber with Flexible Design

Seal chamber accepts a wide range of sealing technologies, including packing, cartridge triple-lip seal and cartridge mechanical seal

Rear Plate with Jacketing

Provides jacketing behind the rotor to eliminate cold spots

Internal Clearance Options

A wide range of internal clearance options are available, which allows optimal performance in a wide range of applications

High-Strength Rotor Standard

High-strength, ductile-iron rotor comes standard on all sizes, eliminating the need for costly, long lead-time steel rotors

Jacketed Head with PRV

Jacketed head designed to incorporate an optional pressure relief valve (PRV), offering pressure protection with improved head heating

Hardened Idler Pin

Standard on all pump sizes for maximized operational life

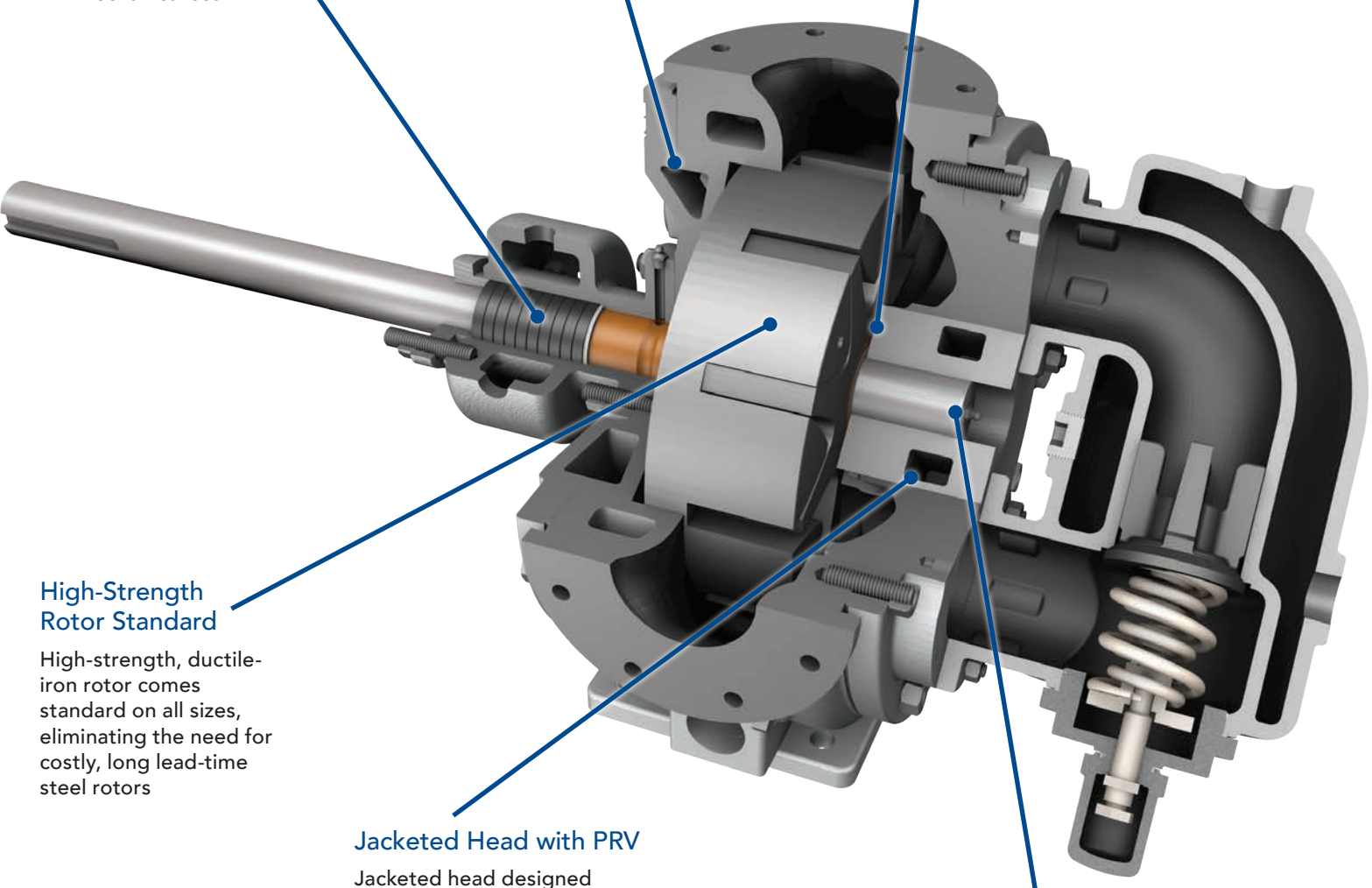

EnviroGear® V Series | Applications

Asphalt and Bitumen Applications

Unlike competitive pumps that are just “good enough” to get the job done, EnviroGear V Series Internal Gear Pumps feature targeted design enhancements that make them ideal for the challenges inherent in the handling and transfer of asphalt and bitumen products.

Roofing Application

Roofing material production is a year-round process with little to no down-time for maintenance, thus posing challenges for the equipment and pumps. The pumps must have very robust designs to handle the variety of bitumen products being moved to various spots in the production process. The EnviroGear V Series incorporates hardened bushings and pump options such as standard high strength ductile iron internal components which provide longer life in applications such as filled asphalt.

Hot-Mix Application

V Series Internal Gear pumps are the first-choice pumping technology in hot-mix asphalt (HMA) manufacturing. HMA paving materials consist of a blend of high-quality aggregates of various sizes and liquid asphalt cement. The materials are heated and mixed in order to produce HMA, which can be manufactured at any of four (4) different types of mix plants – batch, continuous, parallel-flow drum and counterflow drum.

The main challenge in the manufacture of HMA is the temperature variances that can alter its viscosity, which have the capability to rapidly change it from a liquid to a solid. These viscosity changes make it extremely difficult for standard pump technologies to pump HMA. The V Series pumps overcome these challenges and feature:

- Industry-leading jacket surface area
- High-strength ductile iron gear materials
- Wide range of internal component material options
- Flexible sealing configurations

EnviroGear V Series pumps are ideal for hot-mix production including bulk transfer and metering applications.

Emulsion Application

Throughout the asphalt emulsion process, internal gear technology is used in its production. Standard EnviroGear V Series technology is used for the transfer of polymers and chemicals used in the emulsifying process.

The EnviroGear V Series Pump with standard high strength ductile iron components, increased jacketed surface area and internal component options (including hardened bushings) are well suited for un-loading/loading, transfer and metering of asphalt emulsions.

World-Class Manufacturing Facility

- **Manufacturing:** All EnviroGear Pumps are assembled and tested in Grand Rapids, Michigan USA.
- **Supply Chain:** Every component that goes into an EnviroGear Pump is put through a rigid Production Part Approval Process (PPAP) that ensures quality and reliability.
- **Quality Manufacturing:** 100% of EnviroGear Pumps are tested for flow, pressure and power before leaving the factory. The facilities are ISO 9001/14001 compliant, and feature state-of-the-art coordinate-measuring machines and 3D-scanning equipment that ensure the highest level of part quality.
- **Testing Capabilities:** The R&D and testing laboratory is compliant to Hydraulic Institute 3.6 Standards, providing certified performance, NPSH and hydrostatic testing.
- **Global Support:** A full-service global distribution network is ready to serve new or existing EnviroGear Pump installations and is backed by responsive factory support.

Warranty Info

All EnviroGear products (pumps, accessories and parts) are backed with an industry leading five year warranty. Each and every product manufactured by EnviroGear® Pumps is built to meet the highest standards of quality. EnviroGear Pumps warrants that pumps, accessories and parts manufactured or supplied by it to be free from defects in material and workmanship. For more details please refer to the Installation Operation Maintenance Manual.

Delivery

How soon do you want your EnviroGear V Series Gear Pump and parts? EnviroGear builds and ships out equipment fast. EnviroGear Pumps have a 15-day lead time. Our parts have a 5-day lead time, and our basemounted units have a 20-day lead time. Can the other brands do that?

Industry Leading Customer Service and Factory Support



5-Year Limited
Warranty



15 Day Factory Lead
Time for Pumps



5 Day Factory Lead
Time for Parts



Competitive Prices



ATEX, CE and
TR CU Compliant

EnviroGear® V Series | Technical Data

Sizes Available

PUMP MODEL	PORT SIZES ¹	PUMP ONLY
V2-55	2-1/2" ANSI	180 lb (82 kg)
V2-133	3" ANSI	350 lb (160 kg)
V2-254	4" ANSI	530 lb (240 kg)
V2-423	5" ANSI	750 lb (340 kg)

¹Flanged connections meet Class 125# ANSI

Pump Selection Performance Criteria

PUMP MODEL	NOMINAL PUMP RATING		¹ MAX DISCHARGE PRESSURE	MAX TEMPERATURE
	RPM	GPM (M ³ /H)	PSIG (BAR)	FAHRENHEIT (CELCIUS)
V2-55	420	90 (20)	100 (6.9) >20 cSt	450° (232°)
V2-133	350	200 (45)	75 (5.2) >20 cSt	450° (232°)
V2-254	280	280 (64)	75 (5.2) >20 cSt	450° (232°)
V2-423	280	450 (102)	75 (5.2) >20 cSt	450° (232°)

¹Maximum pressure listed reflects maximum differential pressure and maximum allowable working pressure

²Values listed in table are nominal and for reference only. To ensure proper pump selection, always refer to EnviroGear CHOICE.

Materials of Construction

DESCRIPTION	PART	CAST IRON
Pressure Containing Components	Pressure Relief Valve	Cast Iron, ASTM A48, Class 35B
	Head	Cast Iron, ASTM A48, Class 35B
	Case	Cast Iron, ASTM A48, Class 35B
	Bracket	Cast Iron, ASTM A48, Class 35B
	Rear Plate	Cast Iron, ASTM A48, Class 35B
	Rotor Bearing Sleeve (RBS)	Cast Iron, ASTM A48, Class 35B
	Packing Gland	Cast Iron, ASTM A48, Class 35B
Product Contact	Idler Gear	Ductile Iron, ASTM A536, Grade 80-55-06
	Rotor	Ductile Iron, ASTM A536, Grade 80-55-06
	Shaft	Carbon Steel, ASTM A311/A311M, Grade 1045, Class B
	Idler Pin	Hardened Steel, ASTM A311/A311M, Grade 1035, Class A/Carburized
	Idler Bushing	Carbon Graphite, Bronze, Tungsten Carbide
	Thrust Washer - Rotating	Hardened Alloy Steel, Grade 52100
	Thrust Washer - Stationary	Bronze, SAE 660, Grade C93200
	RBS Bushing	Bronze, ASTM B505/B505M, Grade C93700
	Retaining Washer	Carbon Steel, ASTM A311/A311M, Grade 1045
Non-Product Contact	Foot	ASTM A36 Steel

Model Cross Reference

V SERIES	G SERIES	E SERIES	VIKING®
V2-55	G1-55	E1-55	LQ34
V2-133	G1-133	E1-133	Q34
V2-254			M34
V2-423			N34

Viking® is a registered trademark of Viking Pump, Inc., a unit of IDEX Corporation.



PSG Grand Rapids
1809 Century Avenue SW
Grand Rapids, MI 49503-1530
USA
P: +1 (616) 241-1611
F: +1 (616) 241-3752
info@envirogearpump.com
envirogearpump.com



Where Innovation Flows

ENV-14000-C-04

Authorized PSG® Partner:

Copyright 2021 PSG®, a Dover company