

CHARACTERISTICS

	STANDARD	AVAILABLE OPTIONS
Technology	Eccentric Disc Mouvex®	
Maximum Flow rate m³/h (GPM)	55 (242.2)	
Displacement per revolution (l / gal)	2.315 (0.528)	
Inlet chamber volume L (gal)	12 (3.170)	
Outlet chamber volume L (gal)	8 (2.113)	
Weight kg (lbs)	232 (512)	
Wet surface m² (in²)	1.66 (2 573)	
Moment of inertia kg.mm² (lbs.in²)	264 888 (905.16)	
Ports	DN 100 ISO PN16 Flanges	4" ANSI150 flanges
Pump heating	None	Heating Jacket
Dimensions mm (in.) (with ISO PN16 flanges)	A	1 083.5 (42.66)
	B	417 (16.42)
	C	640 (25.2)
	D	410 (16.14)
	E	425 (16.73)

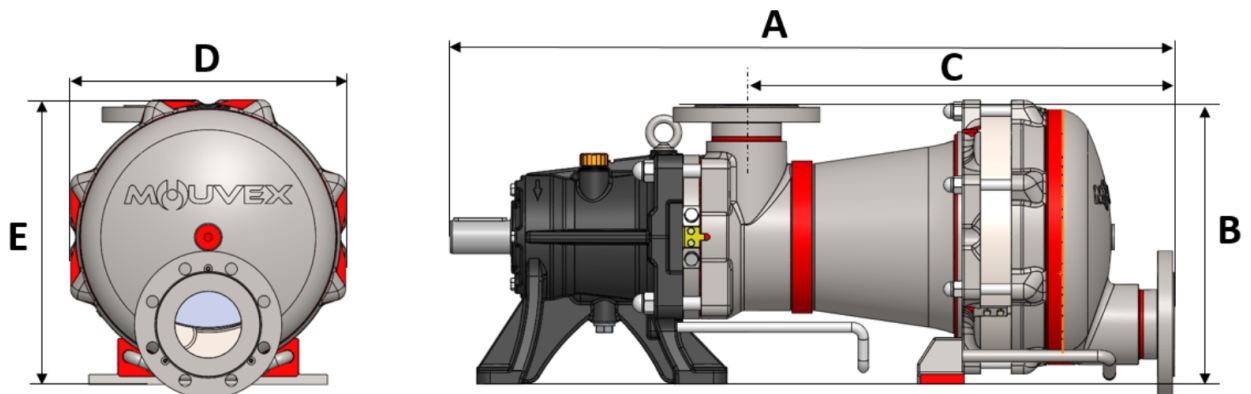

OPERATING LIMITS

Minimum temperature °C (°F)	-15 (5)
Maximum temperature °C (°F)	Process: 100 (212) Washing/Rinsing/Sterilisation: 121 (250)
Maximum dynamic in-pump viscosity cP	10 000
Maximum differential pressure bar (psi)	10 (145)
Maximum inlet pressure barg (psig)	Process : 2 (29) Washing / Rinsing / Sterilisation : 3 (43.5) Pump stopped : 6 (87)
Maximum speed rpm	400
Maximum solid particle size mm (in)	2 (0.0788)
Maximum soft particle size mm (in)	20 (0.787)

MATERIALS OF CONSTRUCTION

Part No	PART NAME	STANDARD MATERIALS	AVAILABLE OPTIONS
39100	Inlet Chamber	316L Stainless Steel	
39108	Inlet chamber Bracket	316L Stainless Steel	
39201	Cylinder	316L Stainless Steel	
39301	Disc	CY5SnBiM (anti galling alloy)	
39304	Disc Nut	316L Stainless Steel	
39401	Outlet Cover	316L Stainless Steel	
39596	Transmission Assembly		
	Bearings	Ball / Roller / Needle	
	Triple layers Bellow Assembly	316Ti & 316 L Stainless Fabrication	
	Housing	Ductile iron + e coating	
	Transmission Lubricant	Synthetic oil	
39206	O-Rings (EC 1935/2004 & FDA)	EPDM	FKM FKM coated FEP

