

EOM

ENGINEERING OPERATION
& MAINTENANCE MANUAL

P1 Clamped Metal Pump

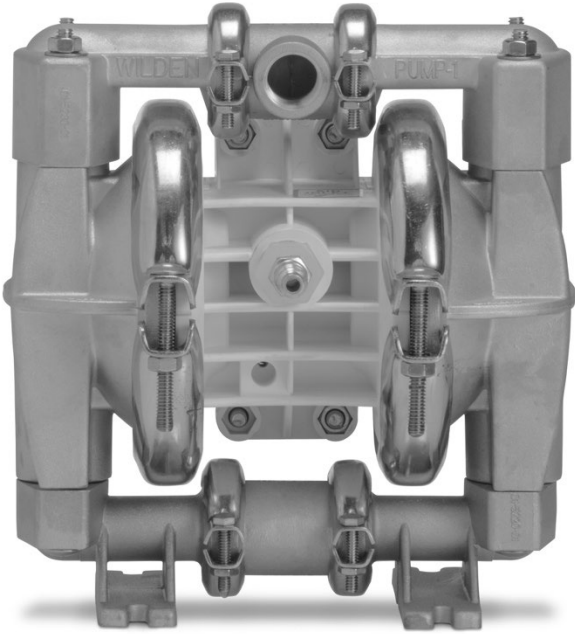

Where Innovation Flows



Copyright

Copyright 2018 PSG®, a Dover Company. All rights reserved.

PSG reserves the right to modify the information and illustrations in this document without prior notice. The product described in this document is furnished under a license agreement or nondisclosure agreement. No part of this document may be reproduced, stored in a retrieval system, or transmitted in any form or any means electronic or mechanical, including photocopying and recording, without the written permission of PSG, a Dover Company, except as described by the terms of those agreements.

This is a non-contractual document.

Trademarks

PSG and the PSG logo are registered trademarks of PSG. Wilden® is a registered trademark of PSG California LLC. Pro-Flo® SHIFT, Pro-Flo®, and Wil-Flex® are registered trademarks of PSG California LLC. Chem-Fuse™, Pure-Fuse™, Saniflex™, and Bunalast™ are trademarks of PSG California LLC.

All trademarks, names, logos and service marks (collectively “trademarks”) in this document are registered and unregistered trademarks of their respective owners. Nothing contained in this document should be construed as granting any license or right to use any trademark without the prior written permission of the trademark owner.

Warranty

Each and every product manufactured by Wilden is built to meet the highest standards of quality. Every pump is functionally tested to ensure integrity of operation. Wilden warrants that pumps, accessories and parts manufactured or supplied by it to be free from defects in material and workmanship for a period of five (5) years from date of installation or six (6) years from date of manufacture, whichever comes first.

For more information, and to register your Wilden pump for warranty, please visit <https://www.psgdover.com/wilden/support/warranty-registration>.

Certifications



CONTENTS

SECTION 1: Precautions – Read First! 4

SECTION 2: Wilden Pump Designation System 5

SECTION 3: How It Works 6

SECTION 4: Dimensional Drawings 7

SECTION 5: Performance 8

 P1 Metal Rubber-Fitted 8

 P1 Metal TPE-Fitted 8

 P1 Metal PTFE-Fitted 9

 Suction Lift Capability 10

SECTION 6: Suggested Installation, Operation, Maintenance, and Troubleshooting 11

SECTION 7: Disassembly/Reassembly 14

 Pump Disassembly 14

 Air Valve Disassembly 17

 Reassembly Hints and Tips 20

 Shaft Seal Installation 21

SECTION 8: Exploded View and Parts List 22

SECTION 9: Elastomer Options 28

SECTION 1

PRECAUTIONS – READ FIRST!

 **WARNING:** Always wear safety glasses when operating a pump to avoid eye injury. If diaphragm rupture occurs, material being pumped may be forced out of the air exhaust.

 **CAUTION:** Do not apply compressed air to the exhaust port – pump will not function.

 **CAUTION:** Do not over-lubricate air supply– excess lubrication will reduce pump performance. Pump is pre-lubed.

 **TEMPERATURE LIMITS:**

Polypropylene	0°C to 79°C	32°F to 175°F
PVDF	-12°C to 107°C	10°F to 225°F
PFA	7°C to 107°C	20°F to 225°F
Neoprene	18°C to 93°C	0°F to 200°F
Buna-N	-12°C to 82°C	10°F to 180°F
EPDM	-51°C to 138°C	-60°F to 280°F
Bunast [™]	-40°C to 130°C	-40°F to 266°F
Geolast [®]	-40°C to 82°C	-40°F to 180°F
FKM	-40°C to 177°C	-40°F to 350°F
Wil-Flex [®]	-40°C to 107°C	-40°F to 225°F
Saniflex [™]	-29°C to 104°C	-20°F to 220°F
Polyurethane	-12°C to 66°C	10°F to 150°F
Polytetrafluoroethylene (PTFE) [†]	4°C to 104°C	40°F to 220°F
Nylon	-18°C to 93°C	0°F to 200°F
Acetal	-29°C to 82°C	-20°F to 180°F
SIPD PTFE with Neoprene-backed	4°C to 104°C	40°F to 220°F
SIPD PTFE with EPDM-backed	-10°C to 137°C	14°F to 280°F
Polyethylene	0°C to 70°C	32°F to 158°F

[†]4°C to 149°C (40°F to 300°F) - 13 mm (1/2") and 25 mm (1") models only.

NOTE: Not all materials are available for all models. See "Wilden Pump Designation System" material options for your pump.

 **CAUTION:** When choosing pump materials, be sure to check the temperature limits for all wetted components. Example: FKM has a maximum limit of 177°C (350°F), but polypropylene has a maximum limit of only 79°C (175°F).

 **CAUTION:** Maximum temperature limits are based on mechanical stress only. Certain chemicals will reduce maximum safe operating temperatures significantly. Consult the Chemical Resistance Guide for chemical compatibility and temperature limits.

 **CAUTION:** All Wilden pumps are capable of passing solids. Use a strainer on the pump intake to ensure that the pump's rated solids capacity is not exceeded.

 **CAUTION:** Do not exceed 8.6 bar (125 psig) air supply pressure.

 **CAUTION:** The process fluid and cleaning fluids must be chemically compatible with all wetted pump components. Consult Chemical Resistance Guide.

 **CAUTION:** Thoroughly flush pumps before installing them into process lines. Clean and/or sanitize FDA- and USDA- approved pumps before using them.

 **CAUTION:** Before attempting any maintenance or repair, disconnect the compressed air line to the pump and allow all air pressure to bleed from the pump. Disconnect all intake, discharge, and air lines. Drain the pump by turning it upside down and allowing any fluid to flow into a suitable container. Be aware of any hazardous effects of contact with your process fluid.

 **CAUTION:** Before attaching the air line to the pump, blow out the air line for 10 to 20 seconds to make sure all pipeline debris is clear. Use an in-line air filter. A 5µ (micron) air filter is recommended.

 **CAUTION:** Pro-Flo pumps cannot be used in submersible applications.

 **CAUTION:** Before installation, tighten all hardware.

 **NOTE:** Materials of construction and elastomer material may influence suction lift parameters. Please refer to "Performance" for specifics.

 **NOTE:** When installing PTFE diaphragms, it is important to tighten outer pistons simultaneously (turning in opposite directions) to ensure tight fit. (See "Maximum Torque Specification").

 **NOTE:** Some PTFE-fitted pumps come standard from the factory with expanded PTFE gaskets installed in the diaphragm bead of the liquid chamber. PTFE gaskets cannot be re-used.

 **NOTE:** In the event of a power failure, close the shut-off valve if you do not want the pump to restart when the power returns.

 **NOTE:** The Safety Supplement document is a part of the manual. Please refer to the Safety Supplement document for a complete list of safety considerations including considerations for safe operation and maintenance of pumps marked for ATEX environments before starting the pump.

 **WARNING:** This product can expose you to chemicals including Nickel, Chromium, Cadmium, or Cobalt, which are known to the State of California to cause cancer and/or birth defects or other reproductive harm. For more information, go to www.P65Warnings.ca.gov.

SECTION 2

WILDEN PUMP DESIGNATION SYSTEM

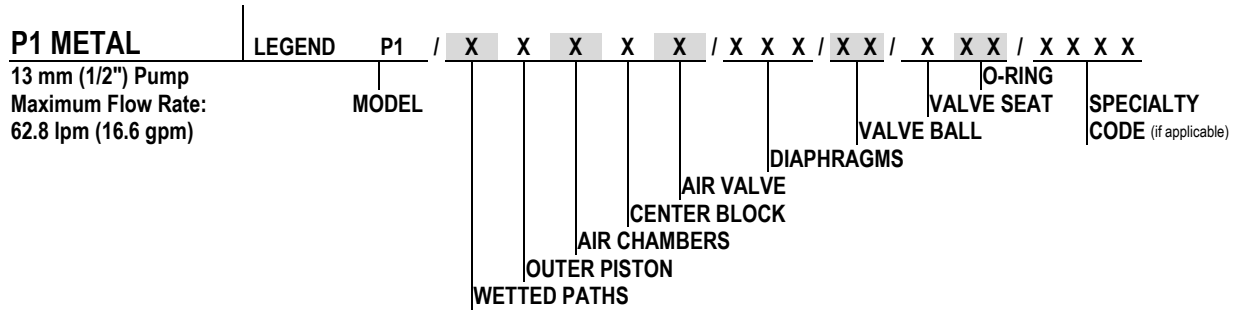

MATERIAL CODES

MODEL P1 = PRO-FLO®	DIAPHRAGMS BNS = BUNA-N (RED DOT) EPS = EPDM (BLUE DOT) FSS = SANIFLEX™ [HYTREL® (CREAM)] ^{1,3} TEU = PTFE W/EPDM BACKUP (WHITE) THU = PTFE W/HIGH-TEMP BUNA-N BACKUP (WHITE) TNU = PTFE W/NEOPRENE BACKUP (WHITE) TNL = PTFE W/NEOPRENE BACKUP, IPD (WHITE) TSU = PTFE W/SANIFLEX™ BACK-UP (WHITE) TVU = PTFE W/FKM BACK-UP VTS = FKM (WHITE DOT) WFS = WIL-FLEX® [SANTOPRENE® (THREE BLACK DOTS)]	VALVE BALLS BN = BUNA-N (RED DOT) EP = EPDM (BLUE DOT) FS = SANIFLEX™ [HYTREL® (CREAM)] ^{1,3} TF = PTFE (WHITE) VT = FKM (SILVER OR WHITE DOT) WF = WIL-FLEX® [SANTOPRENE® (THREE BLACK DOTS)]
WETTED PATH A = ALUMINUM S = STAINLESS STEEL		VALVE SEATS A = ALUMINUM S = STAINLESS STEEL
OUTER PISTON A = ALUMINUM S = STAINLESS STEEL Z = NO OUTER PISTON		VALVE SEATS & MANIFOLD O-RING BN = BUNA-N EP = EPDM FS = SANIFLEX™ [HYTREL® (CREAM)] ^{1,3} TF = PTFE (WHITE) WF = WIL-FLEX® [SANTOPRENE®]
CENTER BLOCK JJ = CONDUCTIVE POLYPROPYLENE PP = POLYPROPYLENE LL = ACETAL		
AIR VALVE J = CONDUCTIVE POLYPROPYLENE P = POLYPROPYLENE L = ACETAL		

REFERENCES:

¹ Meets Requirements of FDA CFR21.177
² Meets Requirements of USP Class VI
³ Meets Requirements of 1935/2004/EC

SPECIALTY CODES

0023 Wing nuts	0103 Wil-Gard II™ 220V	0603 PFA-coated hardware, Wil-Gard 110V
0067 Saniflo™ FDA, Wil-Gard II™ 220V	0120 Saniflo™ FDA, Wil-Gard II™ 110V	0608 PFA-coated hardware, Wil-Gard 220V
0070 Saniflo™ FDA	0206 PFA-coated hardware, Wil-Gard II™ sensor wires ONLY	0067E Saniflo™ FDA, Wil-Gard II™ 220V (1935/2004/EC)
0079 Tri-clamp fittings, wing nuts	0390 CSA-approved	0070E Saniflo™ FDA (1935/2004/EC)
0080 Tri-clamp fittings ONLY	0495 UL-approved	0120E Saniflo™ FDA, Wil-Gard II™ 110V (1935/2004/EC)
0100 Wil-Gard II™ 110V	0502 PFA-coated hardware	
0102 Wil-Gard II™ sensor wires ONLY		

- ! **NOTE:** Most elastomeric materials use colored dots for identification.
- ! **NOTE:** Not all models are available with all material options
- ! **NOTE:** Wilden UL-Listed pumps have been evaluated for use at a 25ÅãC (77ÅãF) ambient temperature with a maximum inlet pressure of 3.4 bar (50 psi).

Hytrel® is a registered trademark of DuPont Dow Elastomers.

SECTION 3

HOW IT WORKS – AIR-OPERATED DOUBLE-DIAPHRAGM PUMP

The Wilden diaphragm pump is an air-operated, positive displacement, self-priming pump. These drawings show flow pattern through the pump upon its initial stroke. It is assumed the pump has no fluid in it prior to its initial stroke.

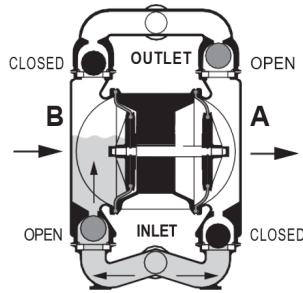

FIGURE 1 The air valve directs pressurized air to the back side of diaphragm A. The compressed air is applied directly to the liquid column separated by elastomeric diaphragms. The diaphragm acts as a separation membrane between the compressed air and liquid; a balanced load removes mechanical stress from the diaphragm. The compressed air moves the diaphragm away from the center of the pump. The opposite diaphragm is pulled in by the shaft connected to the pressurized diaphragm. Diaphragm B is on its suction stroke; air behind the diaphragm has been forced out to atmosphere through the exhaust port of the pump. The movement of diaphragm B toward the center of the pump creates a vacuum within chamber B. Atmospheric pressure forces fluid into the inlet manifold forcing the inlet valve ball off its seat. Liquid is free to move past the inlet valve ball and fill the liquid chamber (see shaded area).

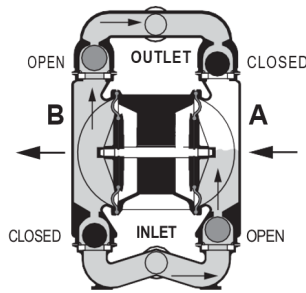

FIGURE 2 When the pressurized diaphragm, diaphragm A, reaches the limit of its discharge stroke, the air valve redirects pressurized air to the back side of diaphragm B. The pressurized air forces diaphragm B away from the center while pulling diaphragm A to the center. Diaphragm B is now on its discharge stroke. Diaphragm B forces the inlet valve ball onto its seat due to the hydraulic forces developed in the liquid chamber and manifold of the pump. These same hydraulic forces lift the discharge valve ball off its seat, while the opposite discharge valve ball is forced onto its seat, forcing fluid to flow through the pump discharge. The movement of diaphragm A toward the center of the pump creates a vacuum within liquid chamber A. Atmospheric pressure forces fluid into the inlet manifold of the pump. The inlet valve ball is forced off its seat allowing the fluid being pumped to fill the liquid chamber.

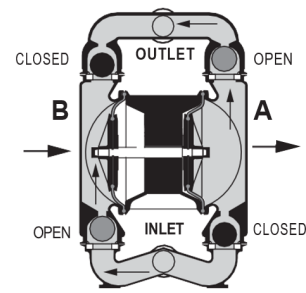
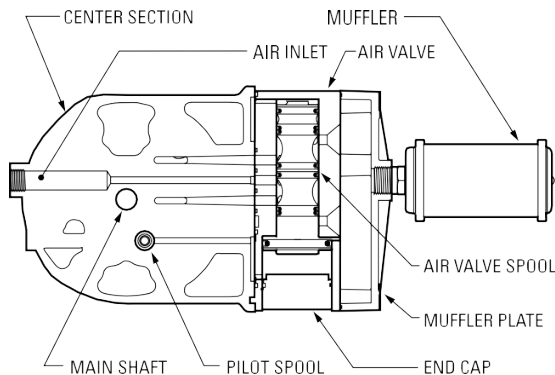

FIGURE 3 At completion of the stroke, the air valve again redirects air to the back side of diaphragm A, which starts diaphragm B on its exhaust stroke. As the pump reaches its original starting point, each diaphragm has gone through one exhaust and one discharge stroke. This constitutes one complete pumping cycle. The pump may take several cycles to completely prime depending on the conditions of the application.

HOW IT WORKS – AIR DISTRIBUTION SYSTEM



The Pro-Flo® patented air distribution system incorporates two moving parts: the air valve spool and the pilot spool. The heart of the system is the air valve spool and air valve. This valve design incorporates an unbalanced spool. The smaller end of the spool is pressurized continuously, while the large end is alternately pressurized then exhausted to move the spool. The spool directs pressurized air to one air chamber while exhausting the other. The air causes the main shaft/diaphragm assembly to shift to one side — discharging liquid on that side and pulling liquid in on the other side. When the shaft reaches the end of its stroke, the inner piston actuates the pilot spool, which pressurizes and exhausts the large end of the air valve spool. The repositioning of the air valve spool routes the air to the other air chamber

SECTION 4

DIMENSIONAL DRAWING

P1 Metal

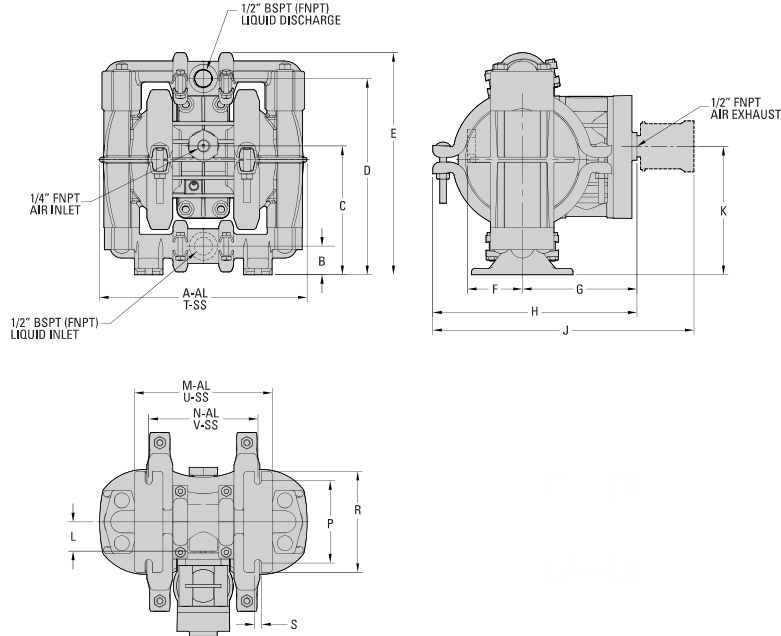

DIMENSIONS

ITEM	METRIC (mm)	STANDARD (inch)
A	208	8.2
B	28	1.1
C	130	5.1
D	198	7.8
E	224	8.8
F	53	2.1
G	114	4.5
H	206	8.1
J	262	10.3
K	130	5.1
L	30	1.2
M	137	5.4
N	109	4.3
P	84	3.3
R	102	4.0
S	8	0.3
T	203	8.0
U	142	5.6
V	114	4.5

LW0403 REV. A

P1 Metal Saniflo™ FDA

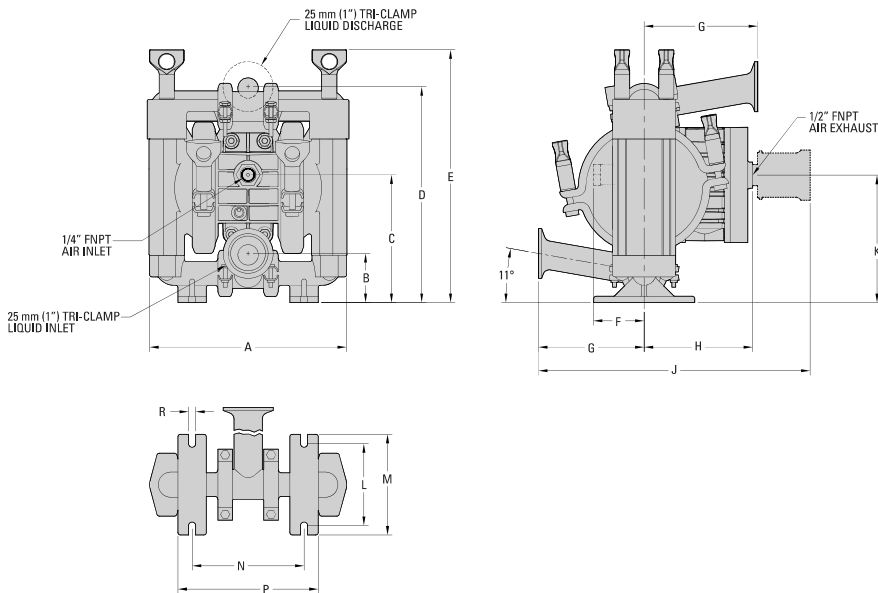

DIMENSIONS

ITEM	METRIC (mm)	STANDARD (inch)
A	203	8.0
B	53	2.1
C	130	5.1
D	218	8.6
E	257	10.1
F	53	2.1
G	114	4.5
H	114	4.5
J	287	11.3
K	130	5.1
L	84	3.3
M	102	4.0
N	114	4.5
P	142	5.6
R	8	0.3

LW0401 REV. B

SECTION 5

**P1 METAL
RUBBER-FITTED**

Ship Weights.....Aluminum 6 kg (13 lb)
 Stainless Steel 9 kg (20 lb)
Air Inlet.....6 mm (1/4")
Inlet.....13 mm (1/2")
Outlet.....13 mm (1/2")
Suction Lift.....5.8 m Dry (19.0')
 9.5 m Wet (31.0')
Disp. per Stroke¹.....0.11 L (0.029 gal)
Max. Flow Rate.....58.7 lpm (15.5 gpm)
Max. Size Solids.....1.59 mm (1/16")

¹Displacement per stroke was calculated at 4.8 bar (70 psig) air inlet pressure against a 2.1 bar (30 psig) head pressure.

Example: To pump 18.9 lpm (5 gpm) against a discharge head of 2.7 bar (40 psig) requires 4 bar (60 psig) and 5.92 Nm³/h (3.5 scfm) air consumption. (See dot on chart.)

**P1 METAL
TPE-FITTED**

Ship Weights.....Aluminum 6 kg (13 lb)
 Stainless Steel 9 kg (20 lb)
Air Inlet.....6 mm (1/4")
Inlet.....13 mm (1/2")
Outlet.....13 mm (1/2")
Suction Lift.....5.2 m Dry (17.0')
 9.5 m Wet (31.0')
Disp. per Stroke¹.....0.11 L (0.029 gal)
Max. Flow Rate.....58.3 lpm (15.4 gpm)
Max. Size Solids.....1.59 mm (1/16")

¹Displacement per stroke was calculated at 4.8 bar (70 psig) air inlet pressure against a 2.1 bar (30 psig) head pressure.

Example: To pump 18.9 lpm (5 gpm) against a discharge head of 2.7 bar (40 psig) requires 4 bar (60 psig) and 5.92 Nm³/h (3.5 scfm) air consumption. (See dot on chart.)

PERFORMANCE

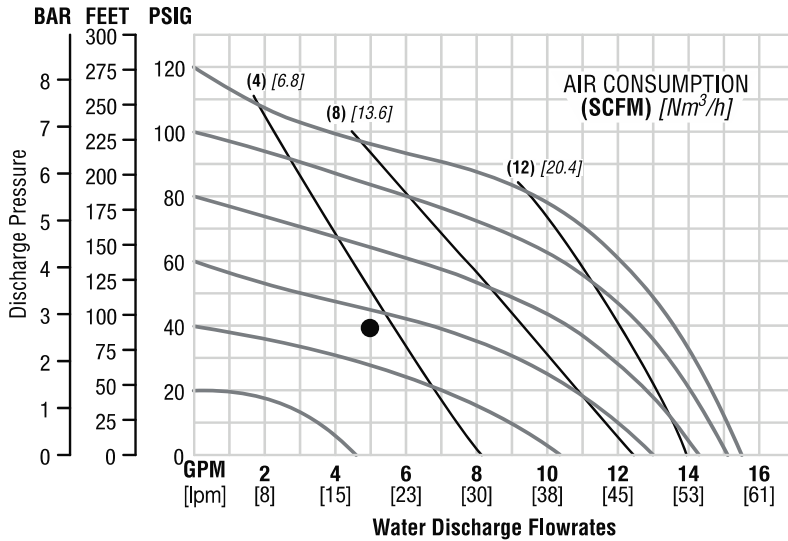

Flow rates indicated on chart were determined by pumping water. For optimum life and performance, pumps should be specified so that daily operation parameters will fall in the center of the pump's performance curve.

Caution: Do not exceed 8.6 bar (125 psig) air supply pressure.

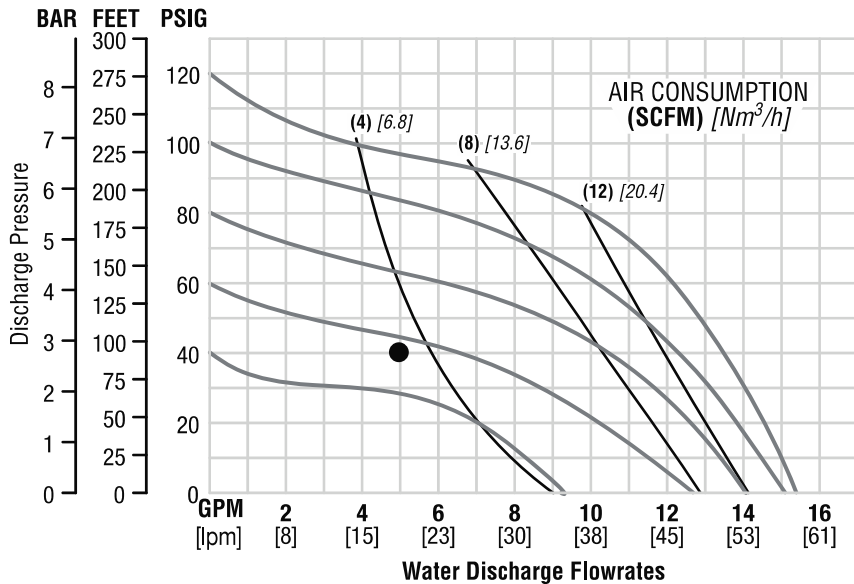

Flow rates indicated on chart were determined by pumping water. For optimum life and performance, pumps should be specified so that daily operation parameters will fall in the center of the pump's performance curve.

Caution: Do not exceed 8.6 bar (125 psig) air supply pressure.

PERFORMANCE

**P1 METAL
PTFE-FITTED**

Ship Weights.....Aluminum 6 kg (13 lb)
 Stainless Steel 9.2 kg (20 lb)
Air Inlet.....6 mm (1/4")
Inlet.....13 mm (1/2")
Outlet.....13 mm (1/2")
Suction Lift.....4.9 m Dry (16.0')
 9.5 m Wet (31.0')
Disp. per Stroke¹.....0.09 L (0.025 gal)
Max. Flow Rate.....54.4 lpm (14.4 gpm)
Max. Size Solids.....1.59 mm (1/16")

¹Displacement per stroke was calculated at 4.8 bar (70 psig) air inlet pressure against a 2.1 bar (30 psig) head pressure.

Example: To pump 18.9 lpm (5 gpm) against a discharge head of 2.7 bar (40 psig) requires 4 bar (60 psig) and 5.92 Nm³/h (3.5 scfm) air consumption.

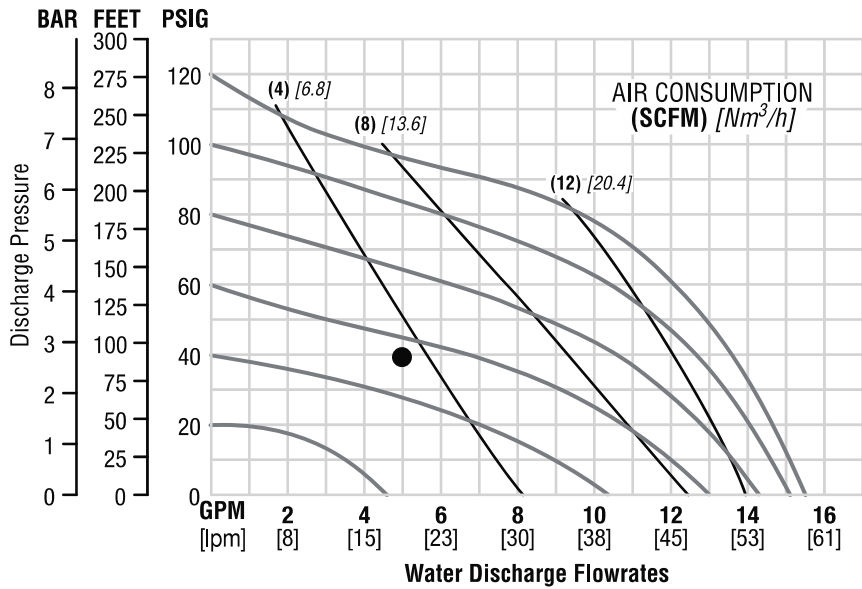

Flow rates indicated on chart were determined by pumping water. For optimum life and performance, pumps should be specified so that daily operation parameters will fall in the center of the pump's performance curve.

Caution: Do not exceed 8.6 bar (125 psig) air supply pressure.

SECTION 5

SUCTION LIFT CAPABILITY

P1 METAL SUCTION-LIFT CAPABILITY

Suction-lift curves are calibrated for pumps operating at 305 m (1,000') above sea level. This chart is meant to be a guide only. There are many variables that can affect your pump's operating characteristics. The number of intake and discharge elbows, viscosity of pumping fluid, elevation (atmospheric pressure) and pipe friction loss all affect the amount of suction lift your pump will attain.

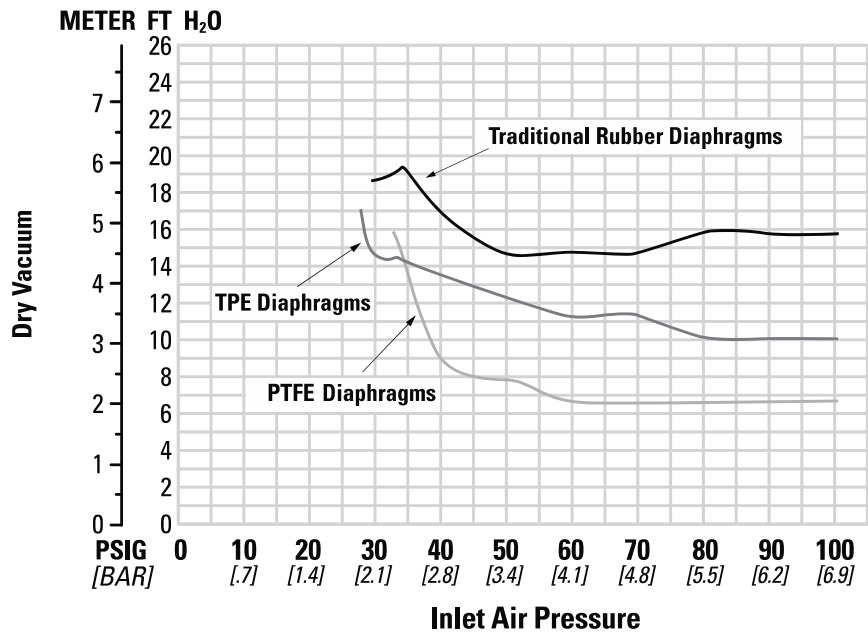

SECTION 6

**SUGGESTED INSTALLATION, OPERATION, MAINTENANCE
AND TROUBLESHOOTING**

Wilden pumps are designed to meet the performance requirements of even the most demanding pumping applications. They have been designed and manufactured to the highest standards and are available in a variety of liquid path materials to meet your chemical resistance needs. Refer to "Performance" for an in-depth analysis of the performance characteristics of your pump. Wilden offers the widest variety of elastomer options in the industry to satisfy temperature, chemical compatibility, abrasion resistance and flex concerns.

The suction pipe size should be at least equal to or larger than the diameter size of the suction inlet on your Wilden pump. The suction hose must be a non-collapsible, reinforced type because these pumps are capable of pulling a high vacuum. Discharge piping should also be equal to or larger than the diameter of the pump discharge, which will help reduce friction losses.

CAUTION: All fittings and connections must be airtight. Otherwise, pump suction capability will be reduced or lost.

Months of careful planning, study and selection efforts can result in unsatisfactory pump performance if installation details are left to chance. You can avoid premature failure and long-term dissatisfaction by exercising reasonable care throughout the installation process.

Location

Noise, safety and other logistical factors usually dictate where equipment will be situated on the production floor. Multiple installations with conflicting requirements can result in congestion of utility areas, leaving few choices for additional pumps. Within the framework of these and other existing conditions, locate every pump in such a way that the following six key factors are balanced against each other to maximum advantage:

- **Access:** First, the location should be accessible. If it's easy to reach the pump, maintenance personnel will be able to perform routine inspections and adjustments more easily. If major repairs become necessary, ease of access can play a key role in speeding the repair process and reducing total downtime.
- **Air Supply:** Every pump location should have an air line large enough to supply the volume of air necessary to achieve the desired pumping rate. For best results, the pumps should use a 5µ (micron) air filter, needle valve and regulator. The use of an air filter before the pump will ensure that the majority of any pipeline contaminants will be eliminated.
- **Solenoid Operation:** When operation is controlled by a solenoid valve in the air line, three-way valves should be used. This valve allows trapped air between the valve and the pump to bleed off, which improves pump performance. You can estimate pumping volume by counting the number of strokes per minute, and then multiplying that figure by the displacement per stroke.
- **Muffler:** Using the standard Wilden muffler, sound levels are reduced below OSHA specifications. You can use other mufflers to reduce sound levels farther, but they usually reduce pump performance.
- **Elevation:** Selecting a site that is well within the pump's dynamic lift capability will assure that loss-of-prime issues will

be eliminated. In addition, pump efficiency can be adversely affected if proper attention is not given to site location.

- **Piping:** Final determination of the pump site should not be made until the piping challenges of each possible location have been evaluated. The impact of current and future installations should be considered ahead of time to make sure that inadvertent restrictions are not created for any remaining sites.

The best choice possible will be a site involving the shortest and straightest hook-up of suction and discharge piping. Unnecessary elbows, bends and fittings should be avoided. Pipe sizes should be selected to keep friction losses within practical limits. All piping should be supported independently of the pump. In addition, the piping should be aligned to avoid placing stress on the pump fittings.

Flexible hose can be installed to aid in absorbing the forces created by the natural reciprocating action of the pump. If the pump is to be bolted down to a solid location, a mounting pad placed between the pump and the foundation will assist in minimizing pump vibration. Flexible connections between the pump and rigid piping will also assist in minimizing pump vibration. If quick-closing valves are installed at any point in the discharge system, or if pulsation within a system becomes a problem, a surge suppressor (SD Equalizer) should be installed to protect the pump, piping and gauges from surges and water hammer.

If the pump is to be used in a self-priming application, make sure that all connections are airtight and that the suction lift is within the model's ability.

NOTE: Materials of construction and elastomer material have an effect on suction lift parameters. Please refer to "Performance" for specifics.

When pumps are installed in applications involving flooded suction or suction head pressures, a gate valve should be installed in the suction line to permit closing of the line for pump service.

Pumps in service with a positive suction head are most efficient when inlet pressure is limited to 0.5–0.7 bar (7–10 psig). Premature diaphragm failure may occur if positive suction is 0.7 bar (10 psig) and higher.

CAUTION: All Wilden pumps are capable of passing solids. Use a strainer on the pump intake to ensure that the pump's rated solids capacity is not exceeded.

CAUTION: Do not exceed 8.6 bar (125 psig) air supply pressure.

CAUTION: Pro-Flo® and Accu-Flo™ pumps do not have single-point exhaust option and are not submersible.

**SUGGESTED INSTALLATION, OPERATION, MAINTENANCE
AND TROUBLESHOOTING**

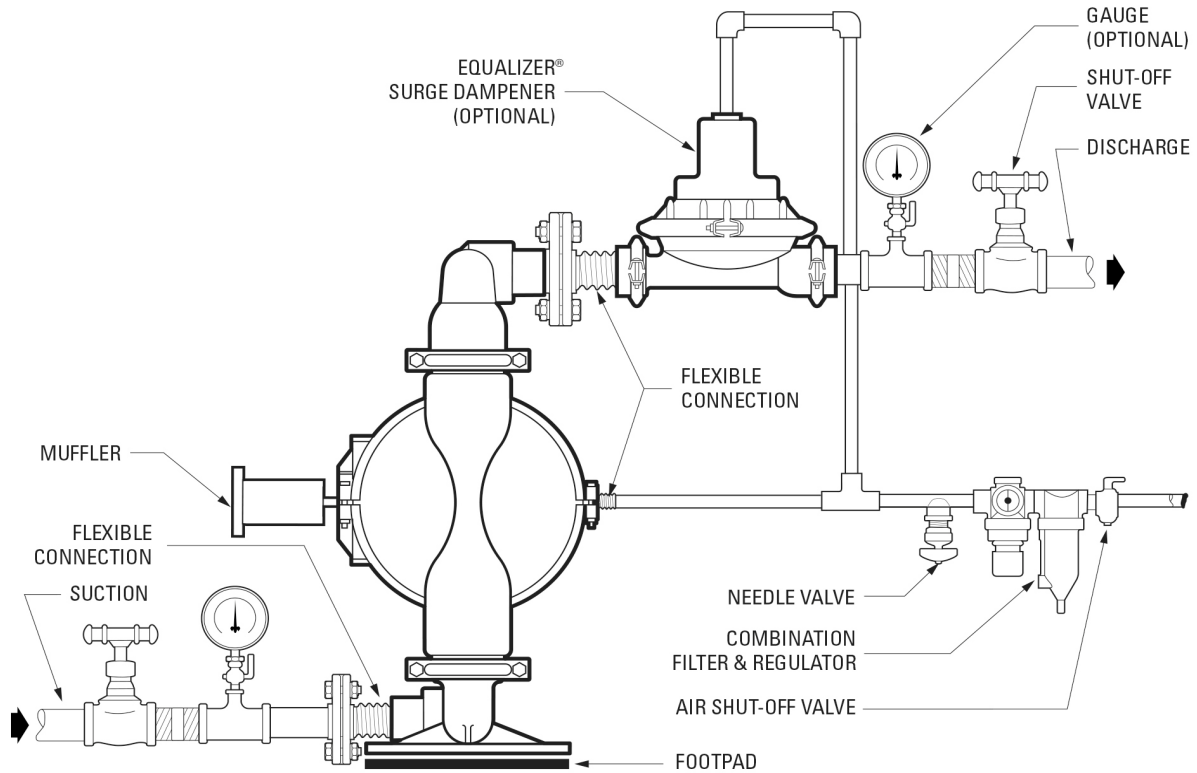

! **NOTE:** In the event of a power failure, close the shut-off valve if you do not want the pump to restart when the power returns.

Air-Operated Pumps: To stop the pump from operating in an emergency, simply close the shut-off valve (user-supplied) installed in the air supply line. A properly functioning valve will stop the air supply to the pump, therefore stopping output. This shut-off valve should be located far enough away from the pumping equipment such that it can be reached safely in an emergency.

Operation

The Pro-Flo pumps are pre-lubricated and do not require in-line lubrication. Additional lubrication will not damage the pump. However, if the pump is heavily lubricated by an external source, the pump's internal lubrication may be washed away. If the pump is then moved to a nonlubricated location, it may need to be disassembled and re-lubricated as described in "Disassembly/ Reassembly".

Pump discharge rate can be controlled by limiting the volume and/or pressure of the air supply to the pump. An air regulator is used to regulate air pressure. A needle valve is used to regulate volume. Pump discharge rate also can be controlled by throttling the pump discharge by partially closing a valve in the discharge line of the pump. This action increases friction loss, which reduces flow rate. (See "Performance") This is useful when the need exists

to control the pump from a remote location. When the pump discharge pressure equals or exceeds the air supply pressure, the pump will stop. No bypass or pressure relief valve is needed, and pump damage will not occur. The pump has reached a "deadhead" situation and can be restarted by reducing the fluid discharge pressure or increasing the air inlet pressure. Wilden Pro-Flo pumps run solely on compressed air and do not generate heat. Therefore, your process fluid temperature will not be affected.

Maintenance and Inspections

Because each application is unique, maintenance schedules may be different for every pump. Frequency of use, line pressure, viscosity and abrasiveness of process fluid all affect the parts life of a Wilden pump. Periodic inspections have been found to offer the best means for preventing unscheduled pump downtime. Personnel familiar with the pump's construction and service should be informed of any abnormalities that are detected during operation.

SUGGESTED INSTALLATION, OPERATION, MAINTENANCE AND TROUBLESHOOTING

Troubleshooting

Pump will not run or runs slowly.

1. Remove plug from pilot spool exhaust.
2. Ensure that the air inlet pressure is at least 0.4 bar (5 psig) above startup pressure and that the differential pressure (the difference between air inlet and liquid discharge pressures) is not less than 0.7 bar (10 psig).
3. Check air inlet filter for debris (see "Suggested Installation, Operation, Maintenance and Troubleshooting").
4. Check for extreme air leakage (blow by) that would indicate worn seals/bores in the air valve, pilot spool and main shaft.
5. Disassemble the pump and check for obstructions in the air passageways or objects that would obstruct the movement of internal parts.
6. Check for sticking ball check valves.
 - a. If material being pumped is not compatible with pump elastomers, swelling may occur. Replace ball check valves and seals with proper elastomers.
 - b. Also, as the check valve balls wear out, they become smaller and can become stuck in the seats. In this case, replace balls and seats.
7. Check for any broken inner piston that would cause the air valve spool to be unable to shift.

Pump runs, but little or no product flows.

1. Check for pump cavitation. Slow pump speed down to allow thick material to flow into liquid chambers.
2. Verify that vacuum required to lift liquid is not greater than the vapor pressure of the material being pumped (cavitation).
3. Check for sticking ball check valves.
 - a. If material being pumped is not compatible with pump elastomers, swelling may occur. Replace ball check valves and seals with proper elastomers.
 - b. Also, as the check valve balls wear out, they become smaller and can become stuck in the seats. In this case, replace balls and seats.

Pump air valve freezes.

1. Check for excessive moisture in the compressed air.
 - a. Either install a dryer or a hot air generator for compressed air.
 - b. Alternatively, you may use coalescing filter to remove the water from the compressed air in some applications.

Air bubbles in pump discharge.

1. Check for a ruptured diaphragm.
2. Check tightness of outer pistons (see "Disassembly/Reassembly").
3. Check tightness of fasteners and integrity of O-rings and seals, especially at intake manifold.
4. Ensure pipe connections are airtight.

Product comes out air exhaust.

1. Check for a diaphragm rupture.
2. Check the tightness of the outer pistons to the shaft.

SECTION 7

DISASSEMBLY / REASSEMBLY

PUMP DISASSEMBLY

Tools Required:

- 3/8" Box Wrench
- 7/16" Wrench
- Adjustable Wrench
- Vise equipped with soft jaws (such as plywood, plastic or other suitable material)



CAUTION: Before attempting any maintenance or repair, disconnect the compressed air line to the pump and allow all air pressure to bleed from the pump. Disconnect all intake, discharge, and air lines. Drain the pump by turning it upside down and allowing any fluid to flow into a suitable container. Be aware of any hazardous effects of contact with your process fluid.



NOTE: Your specific pump model may vary from the configuration shown; however, pump disassembly procedure will be the same.



NOTE: The model used for these instructions incorporates rubber diaphragms and balls. Models with PTFE diaphragms and balls are the same except where noted.



NOTE: Replace worn parts with genuine Wilden parts for reliable performance.

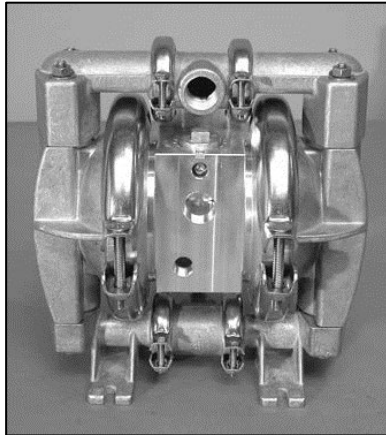

Step 1

Prior to disassembly, alignment marks should be placed on the liquid chambers and air chamber to assist with proper alignment during reassembly.

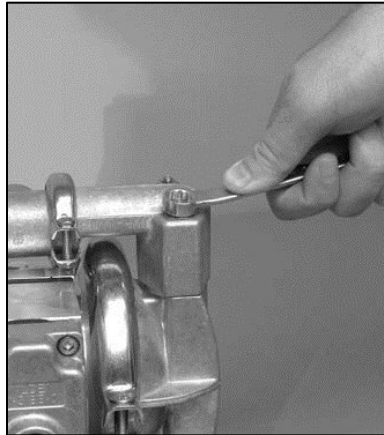

Step 2

Using a 7/16" box wrench, remove the nuts that connect the inlet and discharge manifolds to the center section assembly.

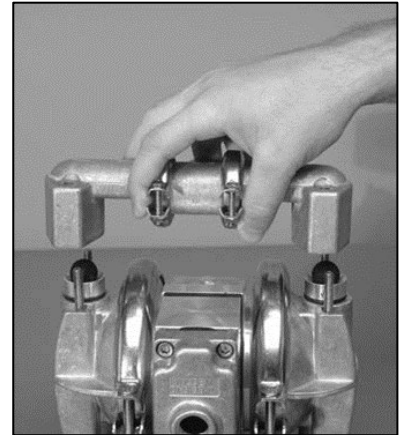

Step 3

Next, remove the discharge manifold from the pump.

DISASSEMBLY / REASSEMBLY

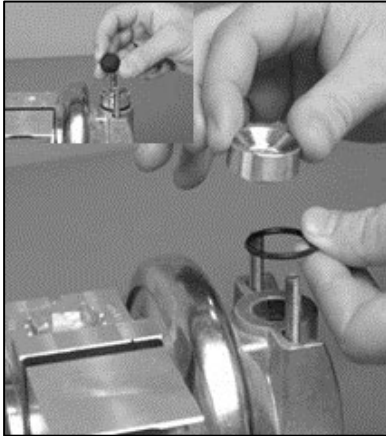

Step 4

Remove the discharge valve ball, valve seat and valve seat O-ring and inspect for signs of wear and replace, if necessary.

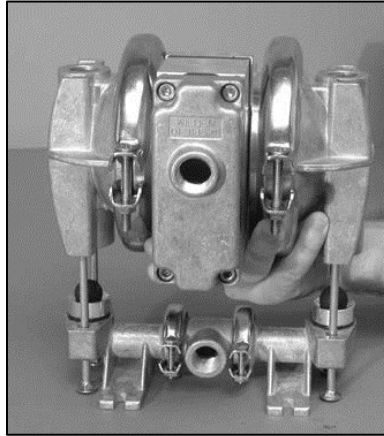

Step 5

Now the center section assembly can be removed from the inlet manifold.

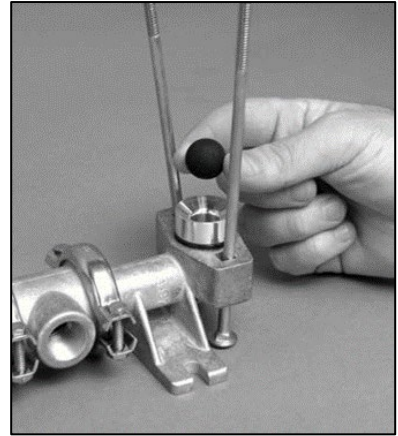

Step 6

Remove the inlet valve balls, seats and valve seat O-rings from the liquid chamber and inlet manifold, inspect for nicks, gouges, chemical attack or abrasive wear.

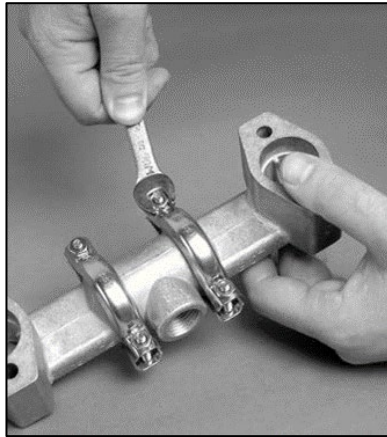

Step 7

Using a 3/8" wrench, remove the small clamp band that connects the manifold elbows to the tee section.

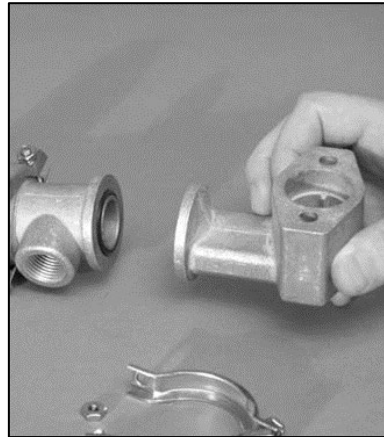

Step 8

Remove the tee section o-rings and inspect for signs of wear and/or chemical attack. Replace, if necessary.

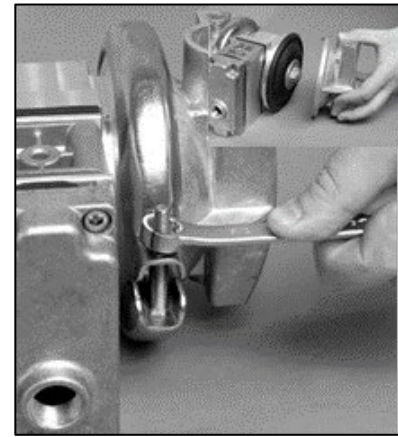

Step 9

Using a 7/16" box end wrench, remove the large clamp bands. With the clamp bands removed, lift the liquid chamber away from the center section.

DISASSEMBLY / REASSEMBLY



Step 10

Using an adjustable wrench or rotating the diaphragm by hand, remove the diaphragm assembly from the center section.

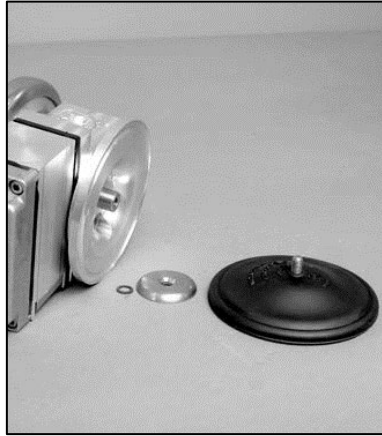

Step 11 A

Due to varying torque values, one of the two situations will occur:

A) The outer piston, diaphragm and inner piston will separate from the shaft which remains connected to the opposite side diaphragm assembly.



Step 11 B

B) The diaphragm assembly and shaft remain connected leaving the opposite side diaphragm assembly within the opposite side of the center section assembly.

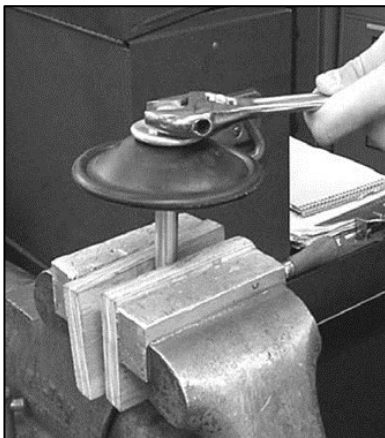

Step 12

To remove the diaphragm assembly from the shaft, secure shaft with soft jaws (a vise fitted with plywood or other suitable material) to ensure shaft is not nicked, scratched or gouged. Using an adjustable wrench, remove the diaphragm assembly from shaft. Inspect all parts for wear and replace with genuine Wilden parts, if necessary.

DISASSEMBLY / REASSEMBLY

AIR VALVE / CENTER SECTION DISASSEMBLY

Tools Required:

- 3/16" Hex Head Wrench
- 7/32" Hex Head Wrench
- Snap-Ring Pliers
- O-Ring Pick



CAUTION: Before attempting any maintenance or repair, disconnect the compressed air line to the pump and allow all air pressure to bleed from the pump. Disconnect all intake, discharge, and air lines. Drain the pump by turning it upside down and allowing any fluid to flow into a suitable container. Be aware of any hazardous effects of contact with your process fluid.



NOTE: Replace worn parts with genuine Wilden parts for reliable performance.



NOTE: For pump Air Valves fitted with Pump Cycle Monitor (PCMI) units, if the Set Screw is removed from the Air Valve Spool and/or the Sensor is removed from the Air Valve End Cap, refer to PCMI EOM WIL-19130-E for reassembly instructions.

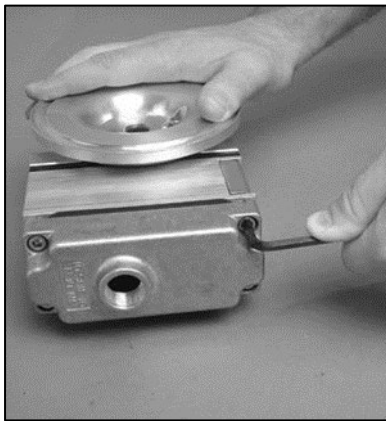

Step 1

Loosen the air valve bolts utilizing a 3/16" Hex Head wrench.

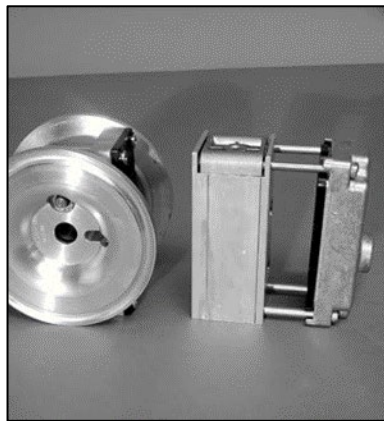

Step 2

Remove muffer plate and air valve bolts from air valve assembly exposing muffer gasket for inspection. Replace if necessary.

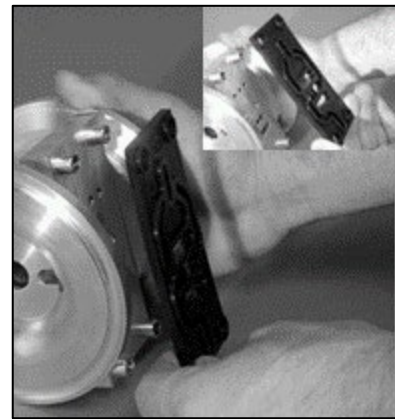

Step 3

Remove the air valve gasket and inspect for nicks, gouges and chemical attack. Replace if necessary with genuine Wilden parts.



NOTE: When installing the air valve gasket onto the center section assembly, position gasket with the grooved side facing away from the center section.

DISASSEMBLY / REASSEMBLY

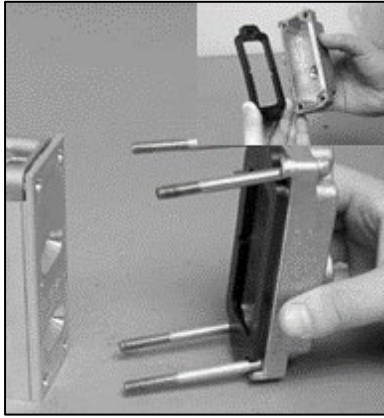

Step 4

Remove air valve spool from air valve body by threading one air valve bolt into the end of the spool and gently sliding the spool out of the air valve body. Inspect seals for signs of wear and replace entire assembly if necessary. Use caution when handling air valve spool to prevent damaging seals.



Step 5

Remove air valve end cap to expose air valve spool.

NOTE: The end cap cannot be removed until removing air valve bolts.

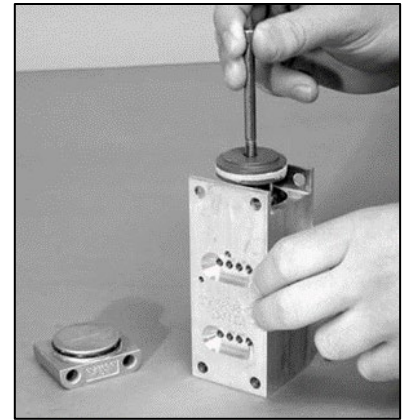

Step 6

Remove air valve spool from air valve body by threading one air valve bolt into the end of the spool and gently sliding the spool out of the air valve body. Inspect seals for signs of wear and replace entire assembly if necessary. Use caution when handling air valve spool to prevent damaging seals.



Step 7

Remove pilot spool retaining snap-ring on both sides of center section with snap-ring pliers.



Step 8

Remove pilot spool bushing from center block.

DISASSEMBLY / REASSEMBLY

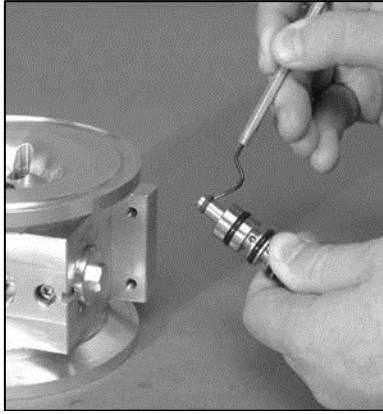

Step 9

Using an O-ring pick, gently remove the pilot spool retaining O-ring from the opposite side of the notched end of the spool. Gently remove the pilot spool from pilot spool sleeve and inspect for nicks, gouges and other signs of wear. Replace pilot spool assembly or outer sleeve O-rings if necessary. During re-assembly never insert the pilot spool into the sleeve with the "notched" end side first, this end incorporates the urethane O-ring and will be damaged as it slides over the ports cut in the pilot spool sleeve.



Step 10

Check center section shaft seals for signs of wear. If necessary, remove the shaft seals with an O-ring pick and replace.

DISASSEMBLY / REASSEMBLY

REASSEMBLY HINTS AND TIPS

Upon performing applicable maintenance to the air distribution system, the pump can now be reassembled. Please refer to the disassembly instructions for photos and parts placement.

To reassemble the pump, follow the disassembly instructions in reverse order. The air distribution system needs to be assembled first, then the diaphragms and finally the wetted path. The applicable torque specifications are on this page.

The following tips will assist in the assembly process:

- Clean the inside of the center section shaft bore to ensure no damage is done to new seals.
- Stainless bolts should be lubed to reduce the possibility of seizing during tightening.
- Level the water chamber side of the intake/discharge manifold to ensure a proper sealing surface. This is most easily accomplished by placing them on a flat surface prior to tightening their clamp bands to the desired torque (see below for Torque Specifications).
- Be sure to tighten outer pistons simultaneously on PTFE-fitted pumps to ensure proper torque values.
- Ensure proper mating of liquid chambers to manifolds prior to tightening vertical bolts. Overhang should be equal on both sides.
- Apply a small amount of Loctite 242 to the shaft interval threads before the diaphragm assembly.
- Concave side of disc spring in diaphragm assembly faces toward shaft.

Maximum Torque Specifications	
Description	Torque
Air Valve, Pro-Flo®	3.1 N•m (27 in-lb)
Outer Piston	14.1 N•m (125 in-lb)
Outer Piston (PTFE with EPDM Backup)	20.3 N•m (15 ft-lb)
Small Clamp Band	1.7 N•m (15 in-lb)
Large Clamp Band (Rubber/ TPE-Fitted)	9.0 N•m (80 in-lb)
Large Clamp Band (PTFE-Fitted)	13.6 N•m (120 in-lb)
Vertical Bolts	14.1 N•m (125 in-lb)

DISASSEMBLY / REASSEMBLY

SHAFT SEAL INSTALLATION

Pre-Installation

After all the old seals have been removed, the inside of the bushing should be cleaned to ensure no debris is left that may cause premature damage to the new seals.

Installation

1. To prevent damaging the inside surface of the new seal, wrap electrical tape around each leg of the needle-nose pliers. (Heat shrink tubing may also be used.)
2. With a new seal in hand, place the two legs of the needle-nose pliers inside the seal ring. (See Figure A.)
3. Open the pliers as wide as the seal diameter will allow, then with two fingers pull down on the top portion of the seal to form a kidney bean shape. (See Figure B.)
4. Lightly clamp the pliers together to hold the seal into the kidney shape. Be sure to pull the seal into as tight of a kidney shape as possible. This will allow the seal to travel down the bushing bore with greater ease.
5. With the seal clamped in the pliers, insert the seal into the bushing bore and position the bottom of the seal into the correct groove. When the bottom of the seal is seated in the groove, release the clamp pressure on the pliers. This will allow the seal to partially snap back to its original shape.
6. After removing the pliers, you will notice a slight bump in the seal shape. Before the seal can be resized properly, the bump in the seal should be removed as much as possible. This can be done with either a Phillips screwdriver or your finger. With the side of the screwdriver or your finger, apply light pressure to the peak of the bump. This pressure will cause the bump to be eliminated almost completely.
7. Lubricate the edge of the shaft with NLGI grade 2 white EP bearing grease.
8. Slowly insert the center shaft with a rotating motion. This will complete the resizing of the seal.
9. Repeat these steps for the remaining seals.

Tools

The following tools can be used to aid in the installation of the new seals:

- Needle-Nose Pliers
- Phillips Screwdriver
- Electrical Tape

Figure A

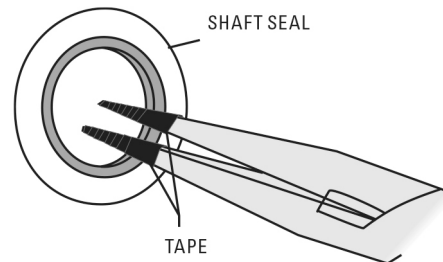
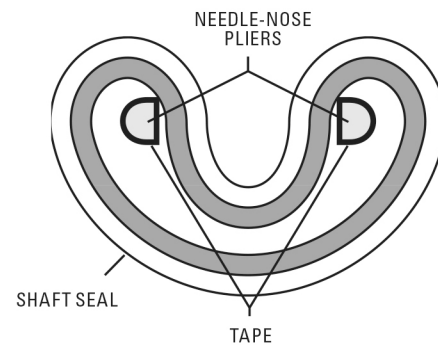

Figure B



SECTION 8

EXPLODED VIEW AND PARTS LIST

P1 METAL – RUBBER/TPE-FITTED

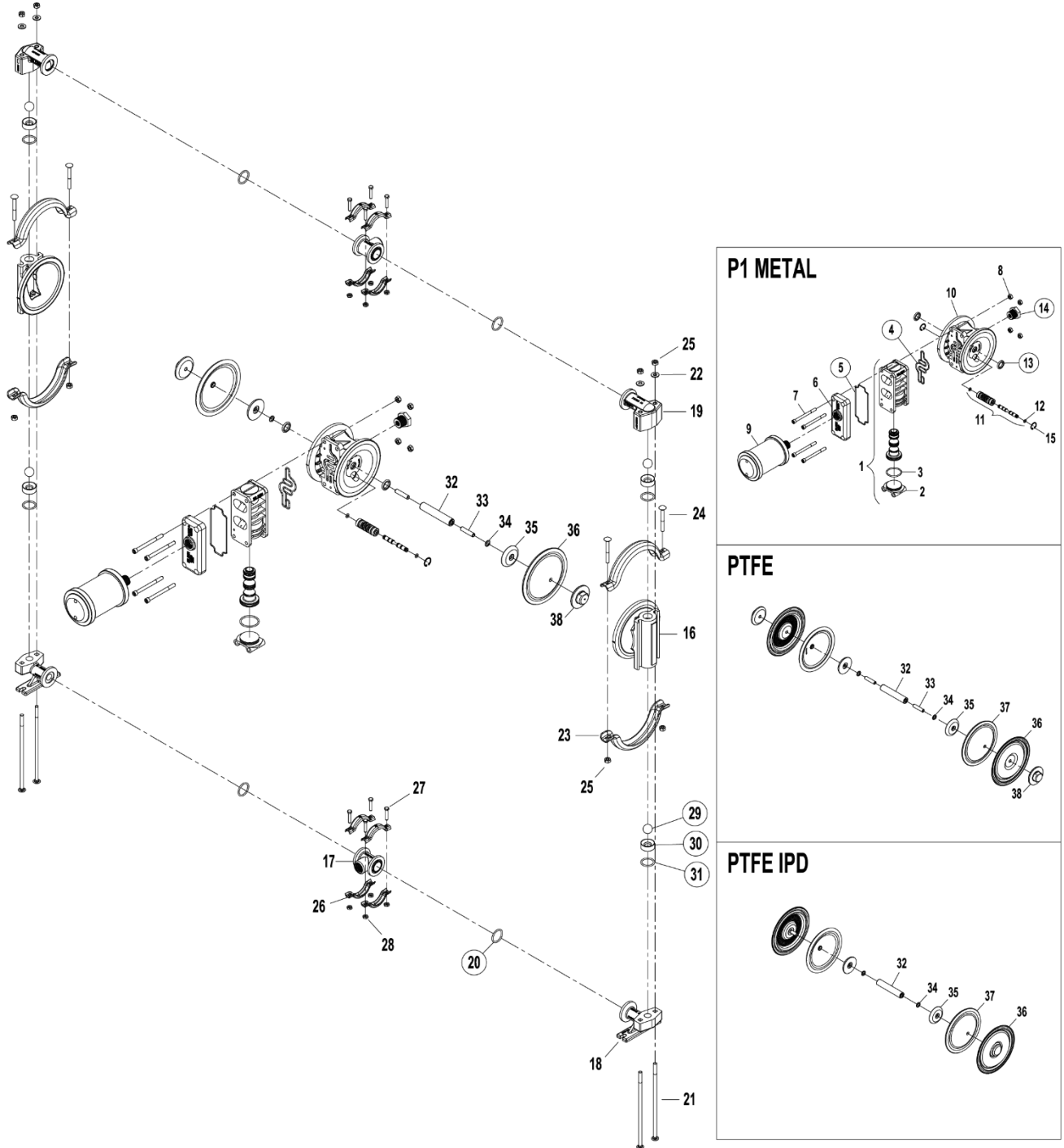

LW0511 Rev. A

EXPLODED VIEW AND PARTS LIST

Item	Part Description	Qty. Per Pump	P1/AALLL/.../ P/N	P1/AAPPP/.../ P/N	P1/AAJJJ/.../ P/N	P1/SLLLL/.../ P/N	P1/SSPPP/.../ P/N	P1/SSJJJ/.../ P/N	P1/SLLLL/.../0070 ³ P/N	P1/SSPPP/.../0070 ³ P/N	P1/SSJJJ/.../0070 ³ P/N
Air Distribution Components											
1	Air Valve Assembly, Pro-Flo 1	1	01-2010-13	01-2010-20	01-2010-25	01-2010-13	01-2010-20	01-2010-25	01-2010-13	01-2010-20	01-2010-25
2	End Cap	1	01-2332-13	01-2332-20	01-2332-25	01-2332-13	01-2332-20	01-2332-25	01-2332-13	01-2332-20	01-2332-25
3	O-Ring (-126), End Cap (Ø1.362" x Ø.103")	1	01-2395-52								
4	Gasket, Air Valve, Pro-Flo™	1	01-2615-52								
5	Gasket, Muffler Plate, Pro-Flo™	1	01-3505-52								
6	Muffler Plate, Pro-Flo™	1	01-3181-13	01-3181-20	01-3181-25	01-3181-13	01-3181-20	01-3181-25	01-3181-13	01-3181-20	01-3181-25
7	Screw, SHC, Air Valve (1/4"-20 x 3")	4	01-6001-03								
8	Hex Nut, (1/4"-20)	4	04-6400-03								
9	Muffler, 1/2" MNPT	1	02-3512-99								
10	Center Section Assembly, Pro-Flo™ 2	1	01-3140-13	01-3140-20	01-3140-25	01-3140-13	01-3140-20	01-3140-25	01-3140-13	01-3140-20	01-3140-25
11	Assembly, Pilot Sleeve	1	01-3880-99								
12	O-Ring (-009), Pilot Spool Retaining (Ø.208" x Ø.070")	2	04-2650-49-700								
13	Seal, Shaft	2	01-3220-55								
14	Bushing, Reducer, 1/2" MNPT to 1/4" FNPT	1	01-6950-13	01-6950-20	01-6950-13	01-6950-20	01-6950-13	01-6950-20	01-6950-13	01-6950-20	
15	Ring, Retaining	2	00-2650-03								
Wetted Path Components											
16	Chamber, Liquid	2	01-5000-01			01-5000-03			01-5000-03P		
17	Manifold, T-Section	2	01-5160-01			01-5160-03			01-5160-03-70P		
18	Elbow, Inlet Manifold	2	01-5220-01			01-5220-03			01-5220-03P		
19	Elbow, Discharge Manifold	2	01-5230-01			01-5230-03			01-5230-03P		
20	O-Ring, Manifold (-120), (Ø.987 x Ø.103)	4	*								
21	Screw, SHCS, (Chamber Bolt) (1/4"-20 x 7-1/2")	4	01-6080-03								
22	Washer, Flat (Ø.281" x Ø.625" x .065")	4	01-6s730-03								
23	Large Clamp Band Assembly	4	01-7300-03								
24	RHSN Bolt, Large Clamp Band (1/4"-20 x 2-1/4")	4	01-6070-03								
25	Wing Nut, (1/4"-20)	8	04-6651-10								
	Hex Nut, Large Clamp Band (1/4"-20)	8	04-6400-03								
26	Small Clamp Band Assembly	8	01-7100-03								
27	HHC Screw, Small Clamp Band (#10-24 x 1")	8	01-6101-03								
28	Hex Nut, Small Clamp Band (#10-24)	8	01-6400-03								
Valve Balls/Valve Seats/Valve O-Rings											
29	Ball, Valve	4	*								
30	Seat, Valve	4	01-1120-01			01-1120-03			01-1120-03P		
31	O-Ring (-119), Valve Seat (Ø.924 x Ø.139)	4	*								
Full Stroke Rubber/TPE/PTFE Components											
32	Shaft	1	01-3810-03								
33	Stud, Shaft (5/16"-18 x 1-3/8")	2						01-6150-03			
34	Spring, Disk (Ø.331" x Ø.512")	2	01-6802-08								
35	Piston, Inner	2	01-3711-08								
36	Diaphragm, Primary	2	*								
37	Diaphragm, Back-Up	2	*								
38	Piston, Outer	2	01-4570-01			01-4570-03			01-4570-03P		
Reduce Stroke PTFE/IPD Components											
32	Shaft	1	01-3810-03								
34	Spring, Disk (Ø.331" x Ø.512")	2	01-6802-08								
35	Piston, Inner	2	01-3711-08								
36	Diaphragm, Primary	2	*								
37	Diaphragm, Back-Up	2	*								

¹Air Valve Assembly includes items 2 and 3.
²Center Section Assembly includes items 13 and 14.
³070 Specialty Code = Saniflo™ FDA
^{*}Refer to corresponding elastomer chart in Section 9.
All boldface items are primary wear parts.

EXPLODED VIEW AND PARTS LIST

P1 METAL – PTFE-FITTED

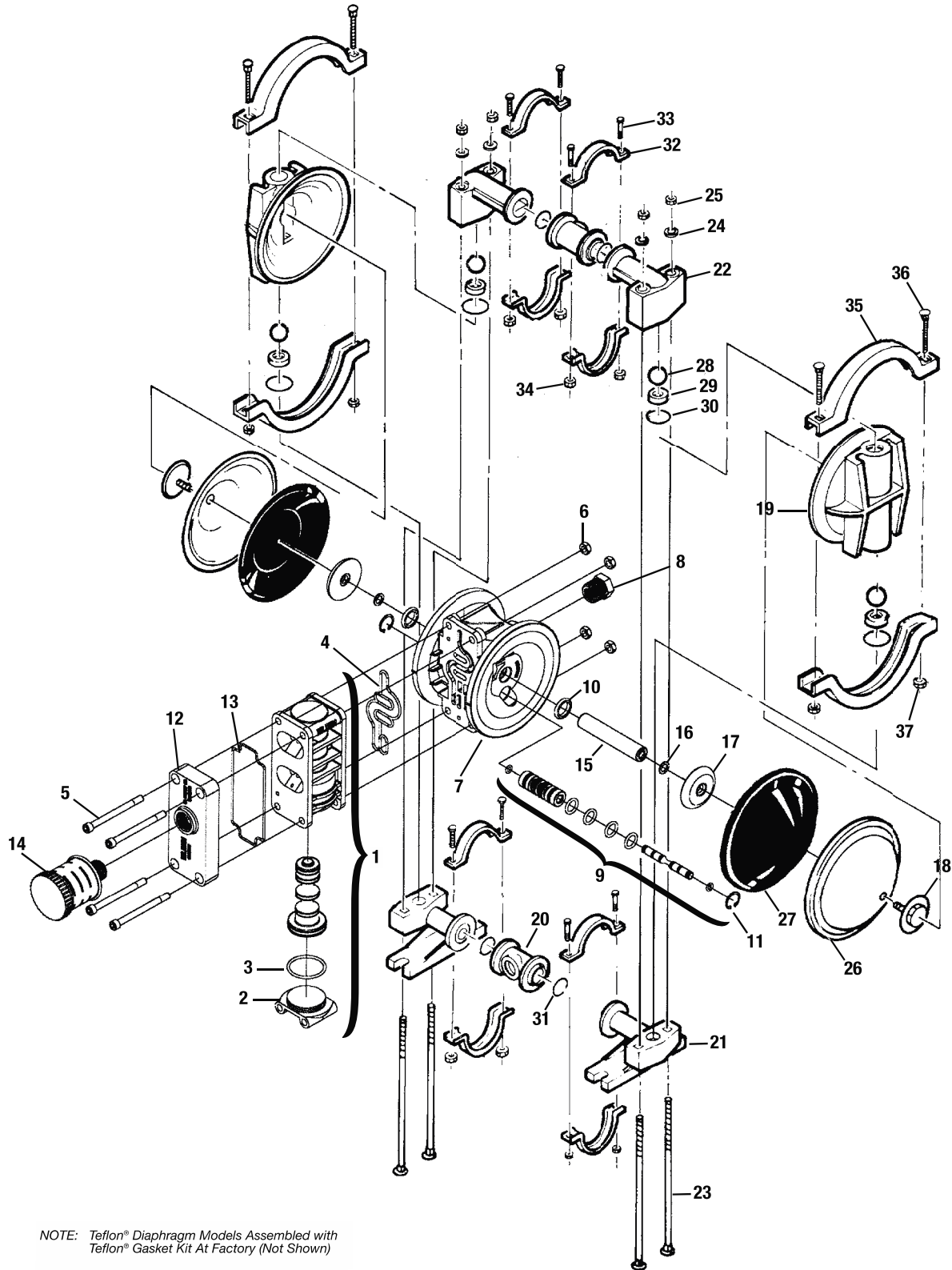

NOTE: Teflon® Diaphragm Models Assembled with Teflon® Gasket Kit At Factory (Not Shown)

EXPLODED VIEW AND PARTS LIST

Item	Part Description	Qty Per Pump	P1/APPP P/N	P1/SPPP P/N	P1/SPPP/070 P/N
1	Pro-Flo™ Air Valve Assembly ¹	1	01-2010-20	01-2010-20	01-2010-20
2	End Cap	1	01-2332-20	01-2332-20	01-2332-20
3	O-Ring (-126) (Ø.1.362 x Ø.103), End Cap	1	01-2395-52	01-2395-52	01-2395-52
4	Gasket, Air Valve	1	01-2615-52	01-2615-52	01-2615-52
5	Screw, HSHC, Air Valve (1/4-20 x 3")	4	01-6001-03	01-6001-03	01-6001-03
6	Nut, Hex, (1/4"-20)	4	04-6400-03	04-6400-03	04-6400-03
7	Center Section Assembly	1	01-3140-20	01-3140-20	01-3140-20
8	Bushing, Reducer	1	01-6950-20	01-6950-20	01-6950-20
9	Removable Pilot Sleeve Assembly	1	01-3880-99	01-3880-99	01-3880-99
10	Shaft Seal	2	01-3220-55	01-3220-55	01-3220-55
11	Retaining Ring	2	00-2650-03	00-2650-03	00-2650-03
12	Muffler Plate	1	01-3181-20	01-3181-20	01-3181-20
13	Gasket, Muffler Plate	1	01-3505-52	01-3505-52	01-3505-52
14	Muffler	1	02-3510-99	02-3510-99	01-3510-99
15	Shaft, Pro-Flo™	1	01-3810-03	01-3810-03	01-3810-03
16	Disc Spring (Belleville Washer)	2	01-6802-08	01-6802-08	01-6802-08
17	Inner Piston	2	01-3711-08	01-3711-08	01-3711-08
18	Outer Piston	2	01-4570-01	01-4570-03	01-4570-03
19	Liquid Chamber	2	01-5000-01	01-5000-03	01-5000-03
20	Manifold Tee Section	2	01-5160-01	01-5160-03	01-5160-03-70
21	Inlet Manifold Elbow	2	01-5220-01	01-5220-03	01-5220-03
22	Discharge Manifold Elbow	2	01-5230-01	01-5230-03	01-5230-03
23	Screw, SHCS (Chamber Bolt) (1/4"-20 x 7 3/8)	4	01-6080-03	01-6080-03	01-6080-03
24	Vertical Bolt Washer (.2811.D. x .6250.D. x .065THR)	4	01-6730-03	01-6730-03	01-6730-03
25	Vertical Bolt Nut (1/4"-20)	4	04-6400-03	04-6400-03	04-6650-03-70
26	PTFE Primary Diaphragm	2	01-1010-55	01-1010-55	01-1010-55
27	Neoprene Backup Diaphragm	2	01-1060-51	01-1060-51	01-1060-51
28	Valve Ball	4	01-1080-55	01-1080-55	01-1080-55
29	Valve Seat	4	01-1120-01	01-1120-03	01-1120-03P
30	Valve Seat (-119) O-Ring (Ø.924 x Ø.103)	4	01-1200-55	01-1200-55	01-1200-55
31	Manifold (-120) O-Ring (Ø.987 x Ø.103)	4	01-1300-55	01-1300-55	01-1300-55
32	Small Clamp Band Assy.	4	01-7100-03	01-7100-03	01-7100-03
33	Small Clamp Band Bolt (#10-24 x 1")	8	01-6101-03	01-6101-03	01-6101-03
34	Small Clamp Band Nut (#10-24)	8	01-6400-03	01-6400-03	01-6400-03
35	Large Clamp Band Assy.	2	01-7300-03	01-7300-03	01-7300-03
36	Large Clamp Band Bolt (1/4"-20 x 2 1/4")	4	01-6070-03	01-6070-03	01-6070-03
37	Large Clamp Band Nut (1/4"-20)	4	04-6400-03	04-6400-03	04-6650-03-70
	Wing Nut	4			04-6651-10

¹Air Valve Assembly includes items 2 and 3.

*Refer to corresponding elastomer chart in Section 10.

0070 Specialty Code = SanifloFDA

All boldface items are primary wear parts.

EXPLODED VIEW AND PARTS LIST

P1 METAL SANIFLO – 1935 / 2004 / EC

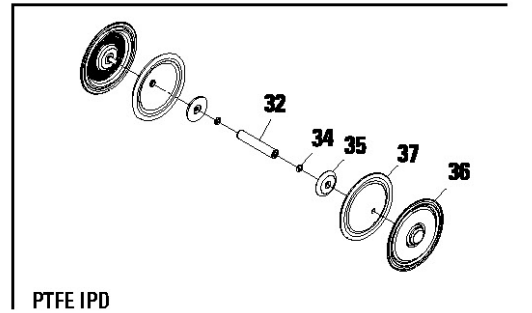
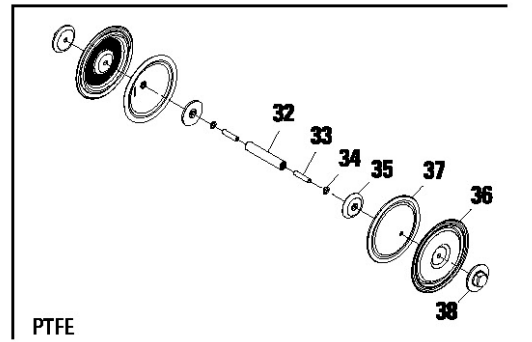
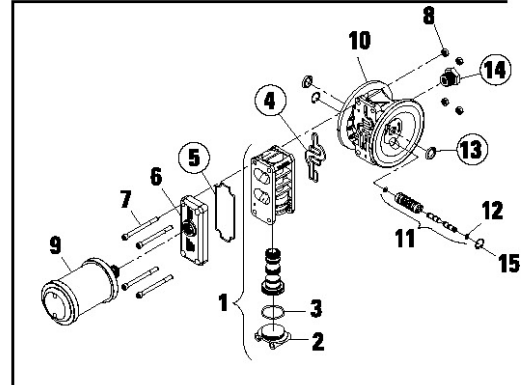
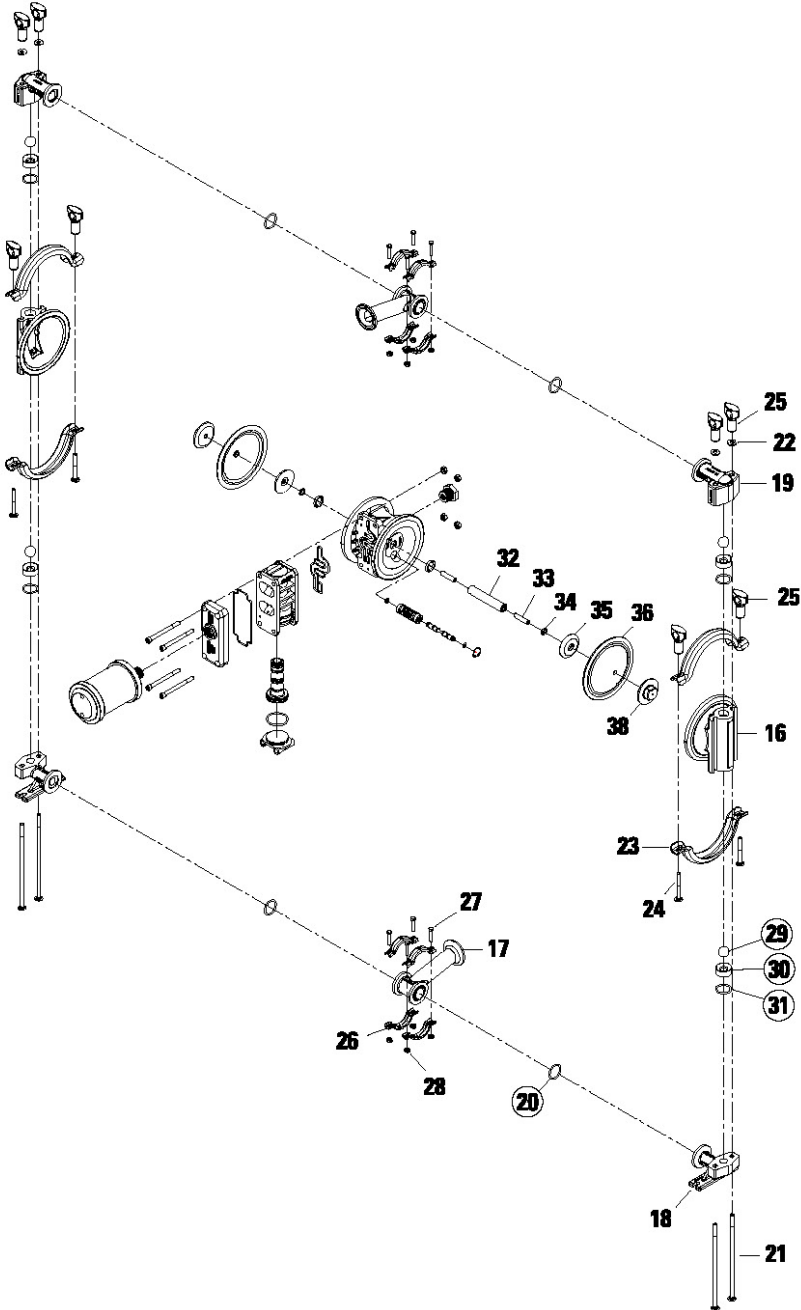

LW0093, Rev. A

EXPLODED VIEW AND PARTS LIST

Item	Description	Qty.	P1/SSL/1935/2004/EC P/N	P1/SSPPP/1935/2004/EC P/N
Air Distribution Components				
1	Air Valve Assembly, Pro-Flo¹	1	01-2010-13	01-2010-20
2	End Cap	1	01-2332-13	01-2332-20
3	O-Ring (-126), End Cap (Ø1.362" x Ø.103")	1	01-2395-52	
4	Gasket, Air Valve, Pro-Flo™	1	01-2615-52	
5	Gasket, Muffler Plate, Pro-Flo™	1	01-3505-52	
6	Muffler Plate, Pro-Flo™	1	01-3181-13	01-3181-20
7	Screw, SHC, Air Valve (1/4"-20 x 3")	4	01-6001-03	
8	Hex Nut, (1/4"-20)	4	04-6400-03	
9	Muffler, 1/2" MNPT	1	02-3510-99	
10	Center Section Assembly, Pro-Flo™ ²	1	01-3140-13	01-3140-20
11	Assembly, Pilot Sleeve	1	01-3880-99	
12	O-Ring (-009), Pilot Spool Retaining (Ø.208" x Ø.070")	2	04-2650-49-700	
13	Seal, Shaft	2	01-3220-55	
14	Bushing, Reducer, 1/2" MNPT to 1/4" FNPT	1	01-6950-13	01-6950-20
15	Ring, Retaining	2	00-2650-03	
Wetted Path Components				
16	Chamber, Liquid	2	01-5000-03P	
17	Manifold, T-Section	2	01-5160-03-70P	
18	Elbow, Inlet Manifold	2	01-5220-03P	
19	Elbow, Discharge Manifold	2	01-5230-03P	
20	O-Ring, Manifold (-120), (Ø.987 x Ø.103)	4	*	
21	Screw, SHCS, (Chamber Bolt) (1/4"-20 x 7-1/2")	4	01-6080-03	
22	Washer, Flat (Ø.281" x Ø.625" x .065")	4	01-6730-03	
23	Large Clamp Band Assembly	4	01-7300-03	
24	RHSN Bolt, Large Clamp Band (1/4"-20 x 2-1/4")	4	01-6070-03	
25	Wing Nut, (1/4"-20)	8	04-6651-10	
26	Small Clamp Band Assembly	8	01-7100-03-70	
27	HHC Screw, Small Clamp Band (#10-24 x 1")	8	01-6101-03	
28	HEX Nut, Small Clamp Band (#10-24)	8	01-6400-03	
Valve Balls/Valve Seats/Valve O-Rings				
29	Ball, Valve, Pkg 4	1	*	
30	Seat, Valve	4	01-1120-03E	
31	O-Ring (-119), Valve Seat (Ø.924 x Ø.139), Pkg 4	1	*	
Full Stroke Rubber/TPE/PTFE Components				
32	Shaft	1	01-3810-03	
33	Stud, Shaft (5/16"-18 x 1-3/8")	2	01-6150-03	
34	Spring, Disk (Ø.331" x Ø.512")	2	01-6802-08	
35	Piston, Inner	2	01-3711-08	
36	Diaphragm, Primary, Pkg 2	1	*	
37	Diaphragm, Back-Up, Pkg 2	1	*	
38	Piston, Outer	2	01-4570-03E	
Reduce Stroke PTFE/IPD Components				
32	Shaft	1	01-3810-03	
34	Spring, Disk (Ø.331" x Ø.512")	2	01-6802-08	
35	Piston, Inner	2	01-3711-08	
36	Diaphragm, Primary, Pkg 2	1	*	
37	Diaphragm, Back-Up, Pkg 2	1	*	

¹ Air Valve Assembly includes items 2 and 3.

² Center Section Assembly includes items 13 and 14.

*Refer to corresponding elastomer chart in Section 9.

070 Specialty Code = Saniflex™FDA

All boldface items are primary wear parts.

LW0082 Rev. A

SECTION 9

ELASTOMER OPTIONS

P1 METAL

Material	Diaphragms	REDUCE STROKE BACK-UP DIAPHRAGMS	REDUCE STROKE IPD DIAPHRAGMS	Valve Ball	Valve Seat O-Rings	Manifold O-Rings
Neoprene		01-1060-51				
Buna-N	01-1010-52			01-1080-52	00-1260-52	01-1300-52
FKM	01-1010-53	01-1060-53		01-1080-53		
EPDM	01-1010-54	01-1060-54		01-1080-54	00-1260-54	01-1300-54
PTFE	01-1010-55		01-1030-55	01-1080-55	01-1200-55	01-1300-55
Saniflex™	01-1010-56	01-1060-56		01-1080-56	01-1200-56	01-1300-56
Wil-Flex™	01-1010-58			01-1080-58	00-1260-58	
High Temp. Buna-N		01-1060-86				

LW0512 Rev. A

P1 METAL SANIFLO™ – 1935 / 2004 / EC

Material	Diaphragms	Reduced-Stroke Backup Diaphragms	Valve Balls	Valve Seats O-Rings	Manifold O-Rings
FDA EPDM		01-1060-54E			
Saniflex™	01-1010-56E	01-1060-56E	01-1080-56E	01-1200-56E	01-1300-56E
PTFE	01-1010-55E		01-1080-55E	01-1200-55E	01-1300-55E

LW0082 Rev. A

WILDEN®

DECLARATION OF CONFORMITY



PSG California LLC, 22069 Van Buren Street, Grand Terrace, CA 92313-5607 USA, certifies as the manufacturer that the Air-Operated Double Diaphragm pumps listed below comply with the following European Community Regulations:

- (EC) 1935/2004 for Food Contact Materials
- (EC) 2023/2006 Good Manufacturing Practice
- (EU) 10/2011 on plastic materials and articles intended to come in contact with food

- **25 mm (1") Saniflo Hygienic™ HS Metal Pump:**
(XPS,PS)2/(SS,SZ)(SSS,NNN)(FBS,FES,FSL,FSS,LEL,TEU,TSS,TSU)(FB,FE,FS,TF)(FB,FE,FV,TF)(0770-0789)E
- **38 mm – 76 mm (1-½"-3") Pro-Flo X Saniflo Hygienic™ HS Metal Pump:**
(PX,XPX)(4,8,15)/(SS,SZ)(SSS,NNN)(BNU,EPU,FBS,FES,FSL,FSS,LEL,TEU,TSS,TSU,ZSS)(FB,FE,FS,FV,SF,TF,TF,TM)(FB,FE,TF)(0770-0789)E
- **38 mm – 76 mm (1-½"-3") Pro-Flo Shift Saniflo Hygienic™ HS Metal Pump:**
(PS,XPS)(4,8,15)/(SS,SZ)(SSS,NNN)(FBS,FES,FSL,FSS,LEL,TSS,ZSS)(FB,FE,FS,FV,SF,TF,TF,TM)(FB,FE,TF)(0770-0789)E
- **76 mm (3") Saniflo HS High Pressure Advanced Metal Pump**
H1500/(SS,SZ)111/(FSL,TSS)(TF,TM)(FE,FV,TF)0770E
- **13 mm (½") Pro-Flo & Pro-Flo X™ Saniflo FDA Metal Pump Models:**
(P,PX,XPX)1/(SS,SZ)(AAA,GGG,JJJ,LLL,PPP)(FSL,FSS,TEU,TSU)(FS,TF)(FS,TF)(0067,0070,0120)E
- **25 mm (1") Pro-Flo Saniflo FDA Metal Pump Models:**
P2/(SS,SZ)(LLL,PPP)(FBS,FES,FSL,FSS,LEL,TEU,TSS,TSU)(FS,TF)(FS,TF)2070E
- **38 mm (1-½") Pro-Flo & Pro-Flo X™ Saniflo FDA Metal Pump Models:**
(P,PX,XPX)4/(SS,SZ)(AAA,LLL,NNN,SSS)(BNU,EPU,FBS,FES,FSL,FSS,TEU,TSS,TSU)(FS,TF)(FS,STF)(0067,0070,0075,0120)E
- **51 mm (2") Pro-Flo & Pro-Flo X™ Saniflo FDA Metal Pump Models:**
(P,PX,XPX)8/(SS,SZ)(AAA,PPP,NNN,SSS)(BNU,EPU,FBS,FES,FSS,TEU,TSU,TSS)(FS,TF)(FS,STF)(0070,0075,0120)E
- **76 mm 3" Pro-Flo X™ Saniflo FDA Metal Pump Models:**
(PX,XPX)15/(SS,SZ)(AAA,NNN,SSS)(BNU,EPU,FSL,FSS,TEU,TSU,TSS)(FS,TF)(FS,STF)(0070,0075,0120)E
- **38 mm 1-½" Pro-Flo Shift™ Saniflo FDA Metal Pump Models:**
XPS4/(SS,SZ)(AAA,NNN,SSS)(FBS,FES,FSL,FSS,TSS,ZSS)(FS,TF)(FS,STF)(0067,0070,0775,0120)E
- **51 mm 2" Pro-Flo Shift™ Saniflo FDA Metal Pump Models:**
XPS8/(SS,SZ)(AAA,NNN,SSS)(FBS,FES,FSL,FSS,TSS,ZSS)(FS,TF)(FS,STF)(0070,0075,0120)E
- **76 mm 3" Pro-Flo Shift™ Saniflo FDA Metal Pump Models:**
XPS15/(SS,SZ)(AAA,NNN,SSS)(FSL,FSS,TSS,ZSS)(FS,SF,TF)(FE,FS,STF)(0070,0120,0341,0770)E

Materials used in equipment that are intended to contact food belong to the groups of materials listed in Annex 1 (EC) 1935/2004 (List of groups of materials and articles which may be covered by specific measures)

- 5) Rubbers 8) Metal and Alloy 10) Plastics

Compliance is subject to material and equipment storage, handling and usage recommended by Wilden in the engineering operation and maintenance manual and supplemental technical publications.

This declaration is based on the following information:

- Statements of raw material from suppliers
- Total Migration Analysis per (EU) 10/2011

Wilden will make available to the competent authorities appropriate documentation to demonstrate compliance

Approved By:

Chris Distaso
Director of Engineering
Date: October 10, 2019



NOTES

NOTES

WILDEN®

PSG
22069 Van Buren Street
Grand Terrace, CA 92313-5651 USA
P: +1 (909) 422 -1730
psgdover.com



Where Innovation Flows

PSG® reserves the right to modify the information and illustrations contained in this document without prior notice. This is a non-contractual document.